

# MODEL DIAGRAM BLOK PADA PADA RANCANGAN PERLAKUAN UNTUK DESAIN FAKTORIAL 4 FAKTOR

Tim Penyusun:

Nely Indra Meifiani, S.Si., M.Pd.

Urip Tisngati, M.Pd.

Dra. Martini, M.Pd.

Dwi Cahyani, Nur Apriyani, M.Pd.

# **MODEL DIAGRAM BLOK pada Rancangan Perlakuan untuk Desain Faktorial 4 Faktor (dilengkapi Model Tabel ANAVA)**

## **Tim Penyusun:**

Nely Indra Meifiani, S.Si., M.Pd.

Urip Tisngati, M.Pd.

Dra. Martini, M.Pd.

Dwi Cahyani, Nur Apriyani, M.Pd.

Diterbitkan Oleh  
LPPM Press STKIP PGRI Pacitan  
Gedung B, Lantai 2 STKIP PGRI Pacitan  
Telp. (0357) 881488  
E-mail: [lppm@stkippacitan.ac.id](mailto:lppm@stkippacitan.ac.id)  
<http://lppm.stkippacitan.ac.id/>



**MODEL DIAGRAM BLOK pada Rancangan Perlakuan untuk Desain Faktorial 4 Faktor (dilengkapi Model Tabel ANAVA)**

Edisi Pertama

Copyright© 2019

ix + 84 hal, 14,5 cm x 21,0 cm

ISBN: 978-602-53557-4-5

Hak Cipta Dilindungi Undang-Undang  
Cetakan Pertama, LPPM Press STKIP PGRI Pacitan

**Penulis**

Nely Indra Meifiani, S.Si., M.Pd.

Urip Tisngati, M.Pd.

Dwi Cahyani Nur Apriyani, M.Pd.

Dra. Martini, M.Pd.

**Editor**

**Dr. Mukodi, M.S.I.**

Diterbitkan Oleh  
LPPM Press STKIP PGRI Pacitan  
Gedung B, Lantai 2 STKIP PGRI Pacitan  
Telp. (0357) 881488  
E-mail: [lppm@stkippacitan.ac.id](mailto:lppm@stkippacitan.ac.id)  
<http://lppm.stkippacitan.ac.id/>

**Dilarang menggandakan, memfotokopi atau memperbanyak sebagian atau seluruh buku ini dengan cara apapun tanpa seizin dari penerbit.**

## KATA PENGANTAR

Puji syukur kehadiran Allah SWT atas segala limpahan rizki-Nya, sehingga buku referensi ini dapat terselesaikan sesuai rencana. Buku ini merupakan salah satu hasil Penelitian Dasar Unggulan Perguruan Tinggi (PDU-PT) dengan judul “Desain Faktorial 4 Faktor”.

Buku ini terdiri dari 6 bab, diawali dengan Bab Pendahuluan, yang menjelaskan latar belakang penelitian, rumusan masalah, dan kontribusi penelitian. Bab selanjutnya membahas tentang: Prinsip Dasar Rancangan Percobaan; Diagram blok untuk semua faktor utama interaksi dan tidak terdapat *Repeated Measurement*; Diagram blok untuk semua faktor utama interaksi dan terdapat *Repeated Measurement*; Diagram blok dengan terdapat ketersarangan pada faktor utama dan tidak terdapat *Repeated Measurement*; dan Diagram blok dengan terdapat ketersarangan pada faktor utama dan terdapat *repeated measurement*.

Buku ini dapat dimanfaatkan oleh peneliti, dosen mahasiswa, guru, dan praktisi pada bidang ilmu sains dan sosial terutama yang memiliki minat meneliti jenis penelitian eksperimen.

Ucapan terima kasih disampaikan kepada Kemenristekdikti, STKIP PGRI Pacitan, mitra penelitian (SMPN 1 Arjosari), dan semua pihak yang telah membantu dan memberikan kontribusi selama penelitian hingga penyusunan laporan serta luaran.

Pacitan, Oktober 2019

Tim Penulis

## DAFTAR ISI

DAFTAR ISI.....	v
DAFTAR TABEL.....	vi
DAFTAR GAMBAR.....	x
BAB I.....	1
PENDAHULUAN.....	1
1. Latar Belakang.....	1
2. Rumusan Masalah.....	2
3. Kontribusi Penelitian.....	3
BAB II.....	4
PRINSIP DASAR RANCANGAN PERCOBAAN.....	4
1. Apakah Rancangan Percobaan Itu?.....	4
2. Unsur-Unsur Dasar Percobaan.....	5
a. Perlakuan ( <i>Treatment</i> ).....	5
b. Unit Percobaan.....	6
c. Satuan amatan.....	6
3. Klasifikasi Rancangan Percobaan.....	6
BAB III.....	8
DIAGRAM BLOK UNTUK SEMUA FAKTOR UTAMA INTERAKSI DAN TIDAK TERDAPAT <i>REPEATED MEASUREMENT</i> .....	8
BAB IV.....	29
DIAGRAM BLOK UNTUK SEMUA FAKTOR UTAMA INTERAKSI DAN TERDAPAT <i>REPEATED MEASUREMENT</i> .....	29
BAB V.....	49
DIAGRAM BLOK DENGAN TERDAPAT KETERSARANGAN PADA FAKTOR UTAMA DAN TIDAK TERDAPAT <i>REPEATED MEASUREMENT</i> ..	49
BAB VI.....	64
DIAGRAM BLOK DENGAN TERDAPAT KETERSARANGAN PADA FAKTOR UTAMA DAN TERDAPAT <i>REPEATED MEASUREMENT</i> .....	64
DAFTAR PUSTAKA.....	78

## DAFTAR TABEL

Tabel 1. Diagram Blok Model 1 Faktor Utama Interaksi dan Tidak Terdapat <i>Repeated Measurement</i> .....	9
Tabel 2 Diagram Blok Model 2 .....	9
Tabel 3 Diagram Blok Model 3 .....	9
Tabel 4 Berbagai Kemungkinan Tabel Anava Faktor Utama Interaksi dan Tidak Terdapat <i>Repeated Measurement</i> .....	10
Tabel 5 Anava model 1 (Faktor ABCD Acak) .....	13
Tabel 6 Anava model 2 (Faktor ABCD Tetap).....	16
Tabel 7 Anava Model 3 (Faktor ABC Acak dan D Tetap) .....	17
Tabel 8 Anava model 4 (Faktor ABD Acak dan C Tetap).....	18
Tabel 9 Anava Model 5 (Faktor ACD Acak dan B Tetap) .....	19
Tabel 10 Anava Model 6 (Faktor BCD acak dan A Tetap) .....	19
Tabel 11 Anava Model 7 (Faktor AB Acak dan CD Tetap) .....	20
Tabel 12 Anava Model 8 (Faktor AC Acak dan BD Tetap) .....	20
Tabel 13 Anava Model 9 (Faktor BC Acak dan AD Tetap) .....	21
Tabel 14 Anava Model 10 (Faktor AD Acak dan BC Tetap) .....	22
Tabel 15 Anava Model 11 (Faktor BD Acak dan AC Tetap) .....	23
Tabel 16 Anava Model 12 (Faktor CD Acak dan AB Tetap) .....	23
Tabel 17 Anava Model 13 (Faktor CD Acak dan AB Tetap) .....	24
Tabel 18 Anava Model 14 (Faktor B acak & A C D tetap) .....	25
Tabel 19 Anava Model 15 (Faktor C Acak & A B D tetap) .....	26
Tabel 20 Anava Model 16 (Faktor D acak & A B C tetap) .....	27
Tabel 21 Diagram Blok Model 1 Faktor Utama Interaksi dan Terdapat <i>Repeated Measurement</i> .....	29
Tabel 22 Diagram Blok Model 2 .....	29
Tabel 23 Diagram Blok Model 3 .....	29
Tabel 24 Diagram Blok Model 4 .....	30
Tabel 25 Diagram Blok Model 5 .....	30
Tabel 26 Diagram Blok Model 6 .....	30
Tabel 27 Berbagai Kemungkinan Tabel Anava Faktor Utama Interaksi dan Terdapat <i>Repeated Measurement</i> .....	34
Tabel 28 Anava Model 1 (Faktor ABCD Acak).....	36
Tabel 29 Anava Model 2 (Faktor ABCD Tetap) .....	40
Tabel 30 Anava Model 3 (Faktor A B C acak & D tetap) .....	41
Tabel 31 Anava Model 4 (Faktor A B D acak & C tetap) .....	42

Tabel 32 Anava Model 5 (Faktor A C D acak & B tetap) .....	42
Tabel 33 Anava Model 6 (Faktor B C D acak & A tetap) .....	42
Tabel 34 Anava Model 7 (Faktor A B Acak & C D Tetap).....	43
Tabel 35 Anava Model 8 (Faktor A C acak & B D tetap) .....	43
Tabel 36 Anava Model 9 (Faktor A C acak & B D tetap) .....	44
Tabel 37 Anava Model 10 (A D acak & B C tetap).....	44
Tabel 38 Anava Model 11 (B D acak & A C tetap) .....	44
Tabel 39 Anava Model 12 (Faktor C D acak& A B tetap) .....	45
Tabel 40 Anava Model 13 (Faktor A acak& B C D tetap) .....	46
Tabel 41 Anava Model 14 (Faktor B acak& A C D tetap) .....	46
Tabel 42 Anava Model 15 (Faktor C acak& A B D tetap) .....	47
Tabel 43 Anava Model 15 (Faktor D acak & A B C tetap) .....	47
Tabel 44 Diagram Blok Model 1: B tersarang A Faktor Utama dan Tidak Terdapat Repeated Measurement .....	50
Tabel 45 Diagram Blok Model 1 B tersarang A .....	50
Tabel 46 Diagram Blok Model 2 C tersarang B .....	50
Tabel 47 Diagram Blok Model 3 C tersarang A dan C tersarang B .....	50
Tabel 48 Diagram Blok Model 4 D tersarang C .....	50
Tabel 49 Diagram Blok Model 5 D tersarang C dan D tersarang B .....	51
Tabel 50 Diagram Blok Model 6 D tersarang A, D tersarang B, dan D tersarang C .....	51
Tabel 51 Diagram Blok Model 7 B tersarang A dan C tersarang B .....	51
Tabel 52 Diagram Blok Model 8 B tersarang A, C tersarang B, dan C tersarang A .....	51
Tabel 53 Diagram Blok Model 9 B tersarang di A, D tersarang di B, dan D tersarang di A .....	52
Tabel 54 Diagram Blok Model 10 B tersarang di A, D tersarang di C, D tersarang di B, dan D tersarang di A.....	52
Tabel 55 Diagram Blok Model 11 C tersarang di B dan D tersarang di C .....	52
Tabel 56 Diagram Blok Model 12 C tersarang di B, D tersarang di C, dan D tersarang di B .....	52
Tabel 57 Diagram Blok Model 13 C tersarang di B, D tersarang di C, D tersarang di B, dan D tersarang di A.....	52
Tabel 58 Diagram Blok Model 14 C tersarang di A, C tersarang di B, dan D tersarang di C .....	53
Tabel 59 Diagram Blok Model 15 C tersarang di A, C tersarang di B, D tersarang di C, dan D tersarang di B.....	53
Tabel 60 Diagram Blok Model 16 C tersarang di A, C tersarang di B, D tersarang di C, D tersarang di B, dan D tersarang di A .....	53

Tabel 61 Berbagai Kemungkinan Tabel Anava Terdapat Ketersarangan pada Faktor Utama dan Tidak Terdapat Repeated Measurement .....	54
Tabel 62 Anava Model 1 (Faktor A B C D semua acak) .....	56
Tabel 63 Anava Model 2 (Faktor A B C D semua tetap) .....	58
Tabel 64 Anava Model 3 (Faktor A B C acak & D tetap) .....	58
Tabel 65 Anava Model 4 (Faktor A B D acak & C tetap) .....	59
Tabel 66 Anava Model 5 (Faktor A C D acak & B tetap) .....	59
Tabel 67 Anava Model 6 (Faktor B C D acak & A tetap) .....	59
Tabel 68 Anava Model 7 (Faktor A B Acak & C D Tetap).....	60
Tabel 69 Anava Model 8 (Faktor A C acak & B D tetap) .....	60
Tabel 70 Anava Model 9 (Faktor B C acak & A D tetap) .....	60
Tabel 71 Anava Model 10 (Faktor A D acak & B C tetap) .....	61
Tabel 72 Anava Model 11 (Faktor B D acak & A C tetap) .....	61
Tabel 73 Anava Model 12 (Faktor C D acak & A B tetap) .....	61
Tabel 74 Anava Model 13 (Faktor A acak & B C D tetap) .....	62
Tabel 75 Anava Model 14 (Faktor B acak & A C D tetap) .....	62
Tabel 76 Anava Model 15 (Faktor C acak & A B D tetap) .....	63
Tabel 77 Anava Model 16 (Faktor D acak & A B C tetap) .....	63
Tabel 78 Diagram Blok Model 1 B tersarang A & R tersarang di C dan R tersarang di D.....	65
Tabel 79 Diagram Blok Model 1 B tersarang A & R tersarang di C dan R tersarang di D.....	65
Tabel 80 Diagram Blok Model 2 C tersarang B & R tersarang di C dan R tersarang di D.....	65
Tabel 81 Diagram Blok Model 3 C tersarang A dan C tersarang B & R tersarang di C dan R tersarang di D.....	65
Tabel 82 Diagram Blok Model 4 D tersarang C & R tersarang di C dan R tersarang di D.....	66
Tabel 83 Diagram Blok Model 5 D tersarang C dan D tersarang B & R tersarang di C dan R tersarang di D.....	66
Tabel 84 Diagram Blok Model 6 D tersarang A, D tersarang B, dan D tersarang C & R tersarang di C dan R tersarang di D .....	66
Tabel 85 Diagram Blok Model 7 B tersarang A dan C tersarang B & R tersarang di C dan R tersarang di D.....	66
Tabel 86 Diagram Blok Model 8 B tersarang A,C tersarang B, dan C tersarang A & R tersarang di C dan R tersarang di D .....	66
Tabel 87 Diagram Blok Model 9 B tersarang di A, D tersarang di B, dan D tersarang di A & R tersarang di C dan R tersarang di D.....	67



Tabel 88 Diagram Blok Model 10 B tersarang di A, D tersarang di C, D tersarang di B, dan D tersarang di A & R tersarang di C dan R tersarang di D .....	67
Tabel 89 Diagram Blok Model 11 C tersarang di B dan D tersarang di C & R tersarang di C dan R tersarang di D .....	67
Tabel 90 Diagram Blok Model 12 C tersarang di B, D tersarang di C, dan D tersarang di B & R tersarang di C dan R tersarang di D .....	67
Tabel 91 Diagram Blok Model 13 C tersarang di B, D tersarang di C, D tersarang di B, dan D tersarang di A & R tersarang di C dan R tersarang di D .....	67
Tabel 92 Diagram Blok Model 14 C tersarang di A, C tersarang di B, dan D tersarang di C & R tersarang di C dan R tersarang di D .....	68
Tabel 93 Diagram Blok Model 15 C tersarang di A, C tersarang di B, D tersarang di C, dan D tersarang di B & R tersarang di C dan R tersarang di D .....	68
Tabel 94 Diagram Blok Model 16 C tersarang di A, C tersarang di B, D tersarang di C, D tersarang di B, dan D tersarang di A & R tersarang di C dan R tersarang di D .....	68
Tabel 95 Anava Model 2 (Faktor A B C D semua tetap) .....	74
Tabel 96 Anava Model 4 (Faktor B tetap, A C D acak) .....	75
Tabel 97 Anava Model 7 (Faktor AB tetap, CD acak) .....	75
Tabel 98 Anava Model 9 (Faktor B C tetap, A D acak) .....	76
Tabel 99 Anava Model 12 (Faktor B D tetap, A C acak) .....	76
Tabel 100 Anava Model 13 (Faktor A B C tetap, D acak) .....	77
Tabel 101 Anava Model 14 (Faktor A B D tetap, C acak) .....	77
Tabel 102 Anava Model 16 (Faktor B C D tetap, A acak) .....	78

## DAFTAR GAMBAR

Gambar 1 Menentukan Sumber Variansi Faktor Utama Interaksi dan Tidak Terdapat <i>Repeated Measurement</i> .....	10
Gambar 2 Menentukan Sumber Variansi Model 1 Faktor Utama Interaksi dan Terdapat <i>Repeated Measurement</i> .....	31
Gambar 3 Menentukan Sumber Variansi Model 2 .....	31
Gambar 4 Menentukan Sumber Variansi Model 3 .....	32
Gambar 5 Menentukan Sumber Variansi Model 4 .....	32
Gambar 6 Menentukan Sumber Variansi Model 5 .....	33
Gambar 7 Menentukan Sumber Variansi Model 6 .....	33
Gambar 8 Menentukan Sumber Variansi Model 1: Terdapat Ketersarangan pada Faktor Utama dan Tidak Terdapat <i>Repeated Measurement</i> .....	54
Gambar 9 Menentukan Sumber Variansi Model 1 Terdapat Ketersarangan pada Faktor Utama dan Terdapat <i>Repeated Measurement</i> .....	69
Gambar 10 Berbagai Kemungkinan Tabel Anava Terdapat Ketersarangan pada Faktor Utama dan Terdapat <i>Repeated Measurement</i> .....	69

# BAB I

## PENDAHULUAN

### 1. Latar Belakang

Rancangan eksperimental adalah rancangan untuk menetapkan unit eksperimental ke tingkat perlakuan dan analisis statistik yang terkait dengan rancangan tersebut (Kirk, 1995: 1). Salah satu rancangan eksperimental adalah desain atau percobaan faktorial. Desain ini memiliki keuntungan, diantaranya adalah, pertama, rancangan faktorial seperti rangkuman dari beberapa rancangan faktor tunggal; kedua, jika terdapat dua faktor A dan B maka faktor A diterapkan untuk setiap tingkat faktor B dan faktor B diterapkan pada setiap tingkat faktor A; ketiga, dalam rancangan faktorial akan diketahui pengaruh faktor-faktor utama yang digabungkan atau efek interaksi (Hanafiah (2011:112).

Pembelajaran selama ini mengajarkan bagaimana membuat bahkan sampai menguji dan menganalisis percobaan atau desain faktorial 2 faktor atau 3 faktor. Akan tetapi kebutuhan para peneliti di lapangan tidak sebatas pada desain faktorial 2 atau 3 faktor. Karena kebutuhan dan permasalahan penelitian yang semakin kompleks dan luas maka dibutuhkan desain faktorial yang bisa menjawab permasalahan tersebut. Sehingga, penulis pada kesempatan ini akan menuliskan hasil penelitian desain faktorial 4 faktor dengan berbagai kombinasi interaksi faktor utama dan dilengkapi dengan ketersarangan pada faktor utama dan replikasinya. Tentunya akan disertakan berbagai kombinasi pemilihan faktor utama Tetap atau Acak

Hasil penelitian sebelumnya telah menjawab 4 macam desain faktorial, yaitu 1) Rancangan faktorial 4 faktor dengan semua faktor utama interaksi dan R (replikasi) yang berbeda untuk setiap selnya (tidak ada *Repeated Measurement*), 2) Rancangan faktorial 4 faktor dengan semua faktor utama interaksi dan terdapat ketersarangan pada R (replikasi) (terdapat *Repeated Measurement*), 3) Rancangan faktorial 4 faktor dengan terdapat ketersarangan pada faktor utama dan R (replikasi) yang berbeda untuk setiap selnya (tidak ada *Repeated Measurement*), 4) Rancangan

faktorial 4 faktor dengan terdapat ketersarangan pada faktor utama dan R (replikasi) (terdapat *Repeated Measurement*) di mana untuk masing-masing rancangan tersebut membahas satu buah model diagram blok dengan masing-masing diagram blok terdiri dari 16 model tabel ANAVA dengan kombinasi pemilihan faktor utama Tetap atau Acak. Sehingga total model yang ditemukan ada 64 model tabel ANAVA. Padahal diagram blok itu sendiri memiliki banyak model. Sedangkan aplikasinya baru terbatas pada dunia pendidikan terbatas untuk diagram blok untuk semua Faktor Utama interaksi dan R (replikasi) yang berbeda untuk setiap sel nya atau tidak terdapat *Repeated Measurement*.

Menganalisis hasil penelitian tahap pertama, ditemukan bahwa pengembangan teori desain faktorial masih terbatas yaitu pada masing-masing rumusan (rumusan 1, 2, 3, dan 4) hanya terbatas pada 1 model diagram blok. Menimbang bahwa karena tuntutan kebutuhan penelitian yang terus berkembang yang butuh dukungan dari perkembangan teori pendukungnya (teori dasar) seperti yang dibahas pada penelitian sebelumnya maka pada tahun kedua akan dikembangkan lagi dengan bahasan yang lebih fokus lagi tetapi bermakna lebih luas yaitu khusus pada pembahasan *Repeated Measurement*, yaitu pada Desain faktorial 4 faktor dengan faktor utama interaksi dan tersarang di mana terdapat *Repeated Measurement* dengan tidak hanya menentukan 1 model saja tetapi menentukan berbagai model untuk masing masing rumusan (rumusan 1 dan rumusan 2). Melalui penelitian dasar ini juga akan diperluas aplikasi teoretisnya tidak hanya pada dunia pendidikan tetapi pada dunia non pendidikan

## **2. Rumusan Masalah**

Berdasarkan latar belakang di atas rumusan masalah yang hendak dibahas adalah:

- 1) Bagaimana model-model Diagram blok untuk semua faktor utama interaksi dan tidak terdapat *Repeated Measurement*?
- 2) Bagaimana model-model Diagram blok untuk semua faktor utama interaksi dan terdapat *Repeated Measurement*?

- 3) Bagaimana model-model Diagram blok dengan terdapat ketersarangan pada faktor utama dan tidak terdapat *Repeated Measurement*?
- 4) Bagaimana model-model Diagram blok dengan terdapat ketersarangan pada faktor utama dan terdapat *repeated measurement*?

### **3. Kontribusi Penelitian**

Berdasarkan latar belakang dan rumusan di atas maka penelitian ini diharapkan menghasilkan temuan atau inovasi keilmuan perancangan percobaan khususnya pada bidang statistika penelitian guna mendukung penelitian terapan dalam tahapan: menemukan prinsip dasar, menyusun formulasi, dan pembuktian rancangan percobaan tentang Diagram Blok Rancangan Faktorial 4 Faktor dan terdapat *Repeated Measurement* secara analitis dan eksperimental

## BAB II

### PRINSIP DASAR RANCANGAN PERCOBAAN

#### 1. Apakah Rancangan Percobaan Itu?

Menurut Hanafiah (2016), percobaan merupakan serangkaian kegiatan di mana setiap tahap dalam rangkaian benar-benar terdefiniskan; dilakukan untuk menemukan jawaban tentang permasalahan yang diteliti melalui pengujian hipotesis. Pola atau tata cara penerapan tindakan-tindakan (perlakuan atau non perlakuan) dalam suatu percobaan pada kondisi/lingkungan tertentu yang kemudian menjadi dasar penataan dan metode analisis statistik terhadap data hasilnya disebut rancangan percobaan (*Experimental Design*)

Biasanya dalam sebuah penelitian kita akan memperoleh dua jenis nilai pengamatan yang lebih kita kenal dengan variabel penelitian. Variabel penelitiannya adalah variabel X dan Y. Variabel X adalah variabel bebas (*Independent Variabel*) dan (*Dependent Variabel*).

Jadi bisa dikatakan bahwa suatu percobaan itu digunakan untuk mengamati pengaruh variabel X terhadap variabel Y. Dan untuk mempermudah pengertian selanjutnya variabel X kita sebut sebagai **Faktor Perlakuan** dan variabel Y kita sebut dengan **Faktor Pengamatan**. Atas dasar ini, nilai-nilai pengamatan dari suatu percobaan dapat disederhanakan menjadi

- a.  $Y = \mu + \sigma_x^2$ , jika penyelidikan dilakukan lewat jalur pengaruh (Analisis Sidik Ragam= *Analysis of Variance*) atau
- b.  $Y = \beta_0 + \beta_1 x$ , jika penyelidikan dilakukam lewat jalur asosiasi (Analisis Regresi dan Korelasi)

Jalur **a** yang ingin ditentukan adalah perlakuan yang diujicobakan, yaitu faktor kuantitatif atau kualitatif, sedangkan jalur **b** perlakuan terbaik (hanya untuk faktor kuantitatif) diterapkan lewat peramalan melalui persamaan regresi yang didapatkan. Perlakuan terbaik pada jalur **b** ini dapat satu perlakuan atau lebih dari satu perlakuan.

$$H_0: \sigma_x = 0 \quad \text{vs} \quad H_0: \sigma_x \neq 0$$

untuk menguji Hipotesis ini diperlukan nilai yang dapat digunakan untuk mengetahui tingkat signifikansi dari X terhadap Y.

Para pakar statistik sependapat bahwa pengaruh perlakuan X akan ada artinya jika pengaruh X ini lebih besar dari pengaruh non perlakuan. Pengaruh nonperlakuan ini timbul jika perlakuan-perlakuan X tersebut diulang hingga  $n$  kali. Ulangan dari perlakuan-perlakuan ini disebut **replikasi** atau **ulangan**. Ragam data akibat pengaruh nonperlakuan ini disebut **galat** (*experimental error*), Hanafiah (2016)

nilai amatan hasil percobaan dinyatakan sebagai berikut:

$$Y = \mu + \tau_j + \varepsilon_{ij}$$

di mana:

$\tau_j$ = pengaruh perlakuan X terhadap nilai-nilai Y

$\varepsilon_{ij}$ =galat akibat adanya pengaruh nonperlakuan (replikasi)  $ke-i$  pada perlakuan  $ke-j$

## 2. Unsur-Unsur Dasar Percobaan

### a. Perlakuan (*Treatment*)

Adalah semua tindakan uji coba yang dilakukan oleh peneliti terhadap objek pengamatan, di mana pengaruhnya diselidiki untuk menguji suatu hipotesis.

Misalkan jenis pupuk yang berbeda, dosis pemupukan yang berbeda, jenis varietas yang berbeda, dan lain-lain.

Perlakuan berdasarkan nilai-nilai yang dicobakan dapat dibedakan menjadi dua, yaitu perlakuan **kuantitatif** dan perlakuan **kualitatif**. Perlakuan kuantitatif yaitu perlakuan yang nilai-nilainya merupakan hasil pengukuran (interval dan rasio), misal dosis. Perlakuan kualitatif yaitu nilai-nilainya merupakan kelas-kelas atau kategori (nominal dan ordinal) seperti jenis varietas padi. Berdasarkan cara pemilihan, perlakuan dibedakan menjadi dua, yaitu perlakuan acak (*random*) dan perlakuan tetap (*fixed*). Pemilihan perlakuan yang berbeda ini juga akan menentukan ANAVanya juga.

b. Unit Percobaan

Merupakan bagian atau unit terkecil dari suatu percobaan yang diberi suatu perlakuan. Unit terkecil itu antara lain petak lahan, individu, dan lain-lain tergantung dari tujuan penelitian

c. Satuan amatan

Satuan amatan adalah anak gugus dari unit percobaan tempat respon diukur. Jika respon yang diukur adalah tinggi tanaman, maka satu tanaman itu adalah satuan amatannya.

a. Faktor

Faktor adalah peubah bebas yang digunakan dalam percobaan sebagai penyusun struktur perlakuan. Peubah bebasnya bisa berupa peubah kualitatif atau peubah kuantitatif. perlakuan dapat disusun oleh beberapa faktor atau peubah bebas. Misalnya perlakuan disusun oleh jenis varietas padi dan jenis pupuk yang diberikan (dua faktor)

b. Taraf/level

Taraf/level adalah banyaknya peubah bebas (faktor) yang diujicobakan. Misalkan dosis pupuk yang dibedakan menjadi 3 taraf, yaitu *0kg/ha*, *50kg/ha*, *100kg/ha*. Atau faktor jenis pupuk yang dibedakan menjadi 2 yaitu pupuk organik dan pupuk anorganik.

### 3. Klasifikasi Rancangan Percobaan

Menurut Mattjik, rancangan percobaan merupakan satu kesatuan antara rancangan perlakuan, rancangan lingkungan, dan rancangan pengukuran. Lebih lanjut, **rancangan perlakuan** merupakan rancangan yang berkaitan dengan bagaimana perlakuan-perlakuan itu dibentuk. Komposisi dari suatu perlakuan dapat dibentuk dari satu faktor, dua faktor, atau lebih. **Rancangan Lingkungan** merupakan rancangan yang berkaitan dengan bagaimana perlakuan-perlakuan tersebut ditempatkan pada unit-unit percobaan. Sedangkan **Rancangan**



**Pengukuran** merupakan rancangan yang membicarakan tentang bagaimana respons percobaan diambil dari unit-unit percobaan yang diteliti.

Secara garis besar Rancangan Percobaan dikategorikan sebagai berikut:

a. Rancangan Perlakuan

1) Satu faktor

2) Dua faktor

a) Faktorial

- Bersilang

- Tersarang

b) Split plot

c) Split blok

3) Tiga faktor

a) Faktorial

- Bersilang

- Tersarang

- Campuran

b) Split-split plot

c) Split-split blok

4) Empat faktor

a) Faktorial

- Bersilang

- Tersarang

- Campuran

b) Split-split-split plot

c) Split-split-split blok

b. Rancangan Lingkungan

- Rancangan Acak Lengkap (RAL)

- Rancangan Acak Kelompok Lengkap (RAKL)

- Rancangan Bujur Sangkar Latin (RBSL)

- Rancangan *Lattice*
  - *Lattice* Seimbang
  - *Tripple Lattice*
  - *Quadruple Lattices*

Pada BAB berikutnya akan dibahas Rancangan Perlakuan untuk Desain Faktorial Empat Faktor di mana perlakuan yang diuraikan ada yang bersilangan, tersarang, dan campuran antara bersilangan dan tersarang.

### **BAB III**

#### **DIAGRAM BLOK UNTUK SEMUA FAKTOR UTAMA INTERAKSI DAN TIDAK TERDAPAT *REPEATED MEASUREMENT***

Tipe diagram blok untuk semua faktor utama interaksi dan tidak terdapat *repeated measurement* merupakan model yang spesial, karena hanya ada 1 kemungkinan Sumber Variansi (SV) dengan 16 kemungkinan tabel ANAVA (*analysis of Variance*) yang mungkin ditemukan. Untuk bab ini diketahui bahwa model diagram bloknya lebih dari satu, akan tetapi mereka hanya memiliki SV yang sama atau hanya memiliki 1 buah SV. Ditunjukkan oleh Tabel 1 sampai Tabel 3.

**Tabel 1.** Diagram Blok Model 1 Faktor Utama Interaksi dan Tidak Terdapat *Repeated Measurement*

		A1		A2	
		B1	B2	B1	B2
C1	D1	R1-R3	R4-R6	R7-R9	R10-R12
	D2	R13-R15	R16-R18	R19-R21	R22-R24
C2	D1	R25-R27	R28-R30	R31-R33	R34-R36
	D2	R37-R39	R40-R42	R43-R45	R46-R48

**Tabel 2 Diagram Blok Model 2**

		A1				A2			
		B1		B2		B1		B2	
		C1	C2	C1	C2	C1	C2	C1	C2
D1	R1-R3	R4-R6	R7-R9	R10-R12	R13-R15	R16-R18	R19-R21	R22-R24	
D2	R25-R27	R28-R30	R31-R33	R34-R36	R37-R39	R40-R42	R43-R45	R46-R48	

**Tabel 3 Diagram Blok Model 3**

A1								A2							
B1				B2				B1				B2			
C1		C2		C1		C2		C1		C2		C1		C2	
D1	D2	D1	D2	D1	D2	D1	D2	D1	D2	D1	D2	D1	D2	D1	D2
R1	R4	R7	R10	R13	R16	R19	R22	R25	R28	R31	R34	R37	R40	R43	R46
-	-	-	-	-	-	-	-	-	-	-	-	-	-	-	-
R3	R6	R9	R12	R15	R18	R21	R24	R27	R30	R33	R36	R39	R42	R45	R48

Langkah selanjutnya setelah menentukan diagram blok adalah melanjutkan dengan menentukan SV. Walaupun ada beberapa model diagram blok, jika dicermati ketiga diagram blok itu sama, hanya saja mereka hanya berubah posisi maka hanya akan ditentukan 1 SV saja.

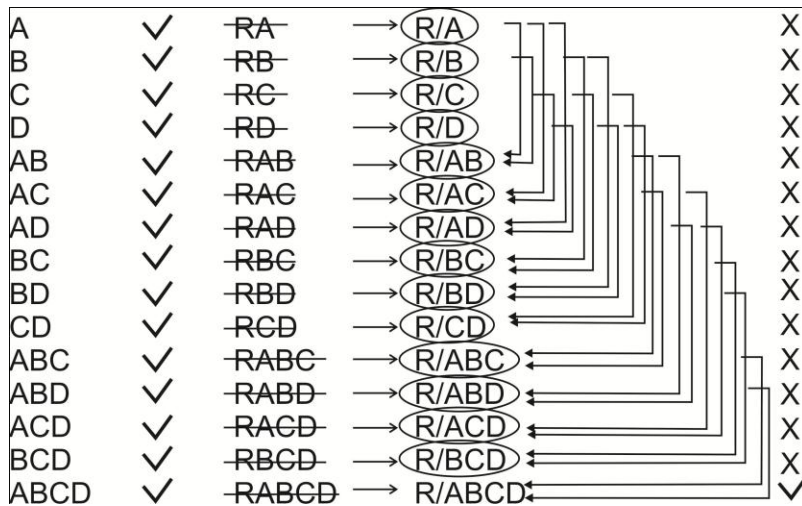

**Gambar 1** Menentukan Sumber Variansi Faktor Utama Interaksi dan Tidak Terdapat *Repeated Measurement*

PETUNJUK/ langkah-langkah menentukan SV

Symbol		Tujuan
<del>RA</del>	Faktor RA dicoret	Diganti
(R/A)	R tersarang pada A dilingkari	Di wakilkan merujuk ke tanda panah
✓	Tanda centang	Faktor Utama yang akan digunakan
X	Tanda silang	Faktor utama yang tidak digunakan

PETUNJUK/ langkah-langkah menentukan F hitung

Blok/ abu-abu	Menghapus
Coret	Menghapus
Anak panah	Menentukan F hitung

Setiap Diagram Blok memiliki 16 kombinasi model tabel ANAVA, yaitu sebagai berikut:

**Tabel 4** Berbagai Kemungkinan Tabel Anava Faktor Utama Interaksi dan Tidak Terdapat *Repeated Measurement*

	<b>FAKTOR</b>			
	<b>Faktor A</b>	<b>Faktor B</b>	<b>Faktor C</b>	<b>Faktor D</b>
Model 1	A	A	A	A
Model 2	T	T	T	T
Model 3	A	A	A	T
Model 4	A	A	T	A
Model 5	A	T	A	A
Model 6	T	A	A	A
Model 7	A	A	T	T
Model 8	A	T	A	T
Model 9	T	A	A	T
Model 10	A	T	T	A
Model 11	T	A	T	A
Model 12	T	A	A	T
Model 13	A	T	T	T
Model 14	T	A	T	T
Model 15	T	T	A	T
Model 16	T	T	T	A

Keterangan :

A : Acak

T : Tetap

Setiap diagram blok memiliki 16 kemungkinan tabel ANAVA yang mungkin bisa dipakai peneliti sebagai dasar untuk menentukan Desain Penelitiannya. Tabel 4 menunjukkan semua kemungkinannya.

Berikut ini adalah semua kemungkinan tabel ANAVA untuk satu buah model diagram blok. Model 1 dan Model 2 akan diberikan tahapan lengkap dalam menentukan Tabel ANAVA. Untuk model lainnya silahkan pembaca menemukannya sendiri sebagai latihan. Cara dan langkah-langkahnya bisa mengikuti petunjuk yang telah diberikan pada buku ini.

### **Model 1. Faktor A B C D semua acak**

Tahapan Menentukan SV

Langkah Pertama



SV	EMS
AD	$\sigma^2_{R/ABCD} + r\sigma^2_{ABCD} + ra\sigma^2_{BCD} + rb\sigma^2_{ACD} + rc\sigma^2_{ABD} + rd\sigma^2_{ABC} + rab\sigma^2_{CD} + rac\sigma^2_{BD} + rad\sigma^2_{BC} + rbc\sigma^2_{AD}$
BC	$\sigma^2_{R/ABCD} + r\sigma^2_{ABCD} + ra\sigma^2_{BCD} + rb\sigma^2_{ACD} + rc\sigma^2_{ABD} + rd\sigma^2_{ABC} + rab\sigma^2_{CD} + rac\sigma^2_{BD} + rad\sigma^2_{BC}$
BD	$\sigma^2_{R/ABCD} + r\sigma^2_{ABCD} + ra\sigma^2_{BCD} + rb\sigma^2_{ACD} + rc\sigma^2_{ABD} + rd\sigma^2_{ABC} + rab\sigma^2_{CD} + rac\sigma^2_{BD}$
CD	$\sigma^2_{R/ABCD} + r\sigma^2_{ABCD} + ra\sigma^2_{BCD} + rb\sigma^2_{ACD} + rc\sigma^2_{ABD} + rd\sigma^2_{ABC} + rab\sigma^2_{CD}$
ABC	$\sigma^2_{R/ABCD} + r\sigma^2_{ABCD} + ra\sigma^2_{BCD} + rb\sigma^2_{ACD} + rc\sigma^2_{ABD} + rd\sigma^2_{ABC}$
ABD	$\sigma^2_{R/ABCD} + r\sigma^2_{ABCD} + ra\sigma^2_{BCD} + rb\sigma^2_{ACD} + rc\sigma^2_{ABD}$
ACD	$\sigma^2_{R/ABCD} + r\sigma^2_{ABCD} + ra\sigma^2_{BCD} + rb\sigma^2_{ACD}$
BCD	$\sigma^2_{R/ABCD} + r\sigma^2_{ABCD} + ra\sigma^2_{BCD}$
ABCD	$\sigma^2_{R/ABCD} + r\sigma^2_{ABCD}$
R/ABCD	$\sigma^2_{R/ABCD}$

**Tabel 5 Anava model 1 (Faktor ABCD Acak)**

SV	Df	Fhitung	Ftabel
ABC	$(a-1)(b-1)(c-1)=1$	$F_{hitung}(ABC) = \frac{KT(ABC)}{KT(ABCD)}$	$F_{\alpha; db(ABC); db(ABCD)}$
ABD	$(a-1)(b-1)(d-1)=1$	$F_{hitung}(ABD) = \frac{KT(ABD)}{KT(ABCD)}$	$F_{\alpha; db(ABD); db(ABCD)}$
ACD	$(a-1)(c-1)(d-1)=1$	$F_{hitung}(ACD) = \frac{KT(ACD)}{KT(ABCD)}$	$F_{\alpha; db(ACD); db(ABCD)}$
BCD	$(b-1)(c-1)(d-1)=1$	$F_{hitung}(BCD) = \frac{KT(BCD)}{KT(ABCD)}$	$F_{\alpha; db(BCD); db(ABCD)}$
ABCD	$(a-1)(b-1)(c-1)(d-1)=1$	$F_{hitung}(ABCD) = \frac{KT(ABCD)}{KT(R/ABCD)}$	$F_{\alpha; db(ABCD); db(R/ABCD)}$
R/ABCD	$(r-1)abcd=32$		

Keterangan:

- A : Faktor A
- B : Faktor B
- C : Faktor C
- D : Faktor D
- A : Banyaknya Faktor A
- B : Banyaknya Faktor B
- C : Banyaknya Faktor C

- D : Banyaknya Faktor D  
R : Banyaknya ulangan  
KT : Kuadrat Total  
Db : derajat bebas

## Model 2. Faktor A B C D semua Tetap

Tahapan Menentukan SV

Langkah pertama

SV	EMS
A	$\sigma^2_{R/ABCD} + r\theta^2_{ABCD} + ra\theta^2_{BCD} + rb\theta^2_{ACD} + rc\theta^2_{ABD} + rd\theta^2_{ABC} + rab\theta^2_{CD} + rac\theta^2_{BD} + rad\theta^2_{BC} + rbc\theta^2_{AD} + rbd\theta^2_{AC} + rcd\theta^2_{AB} + rabc\theta^2_D + rabd\theta^2_C + racd\theta^2_B + rbcd\theta^2_A$
B	$\sigma^2_{R/ABCD} + r\theta^2_{ABCD} + ra\theta^2_{BCD} + rb\theta^2_{ACD} + rc\theta^2_{ABD} + rd\theta^2_{ABC} + rab\theta^2_{CD} + rac\theta^2_{BD} + rad\theta^2_{BC} + rbc\theta^2_{AD} + rbd\theta^2_{AC} + rcd\theta^2_{AB} + rabc\theta^2_D + rabd\theta^2_C + racd\theta^2_B$
C	$\sigma^2_{R/ABCD} + r\theta^2_{ABCD} + ra\theta^2_{BCD} + rb\theta^2_{ACD} + rc\theta^2_{ABD} + rd\theta^2_{ABC} + rab\theta^2_{CD} + rac\theta^2_{BD} + rad\theta^2_{BC} + rbc\theta^2_{AD} + rbd\theta^2_{AC} + rcd\theta^2_{AB} + rabc\theta^2_D + rabd\theta^2_C$
D	$\sigma^2_{R/ABCD} + r\theta^2_{ABCD} + ra\theta^2_{BCD} + rb\theta^2_{ACD} + rc\theta^2_{ABD} + rd\theta^2_{ABC} + rab\theta^2_{CD} + rac\theta^2_{BD} + rad\theta^2_{BC} + rbc\theta^2_{AD} + rbd\theta^2_{AC} + rcd\theta^2_{AB} + rabc\theta^2_D$
AB	$\sigma^2_{R/ABCD} + r\theta^2_{ABCD} + ra\theta^2_{BCD} + rb\theta^2_{ACD} + rc\theta^2_{ABD} + rd\theta^2_{ABC} + rab\theta^2_{CD} + rac\theta^2_{BD} + rad\theta^2_{BC} + rbc\theta^2_{AD} + rbd\theta^2_{AC} + rcd\theta^2_{AB}$
AC	$\sigma^2_{R/ABCD} + r\theta^2_{ABCD} + ra\theta^2_{BCD} + rb\theta^2_{ACD} + rc\theta^2_{ABD} + rd\theta^2_{ABC} + rab\theta^2_{CD} + rac\theta^2_{BD} + rad\theta^2_{BC} + rbc\theta^2_{AD} + rbd\theta^2_{AC}$
AD	$\sigma^2_{R/ABCD} + r\theta^2_{ABCD} + ra\theta^2_{BCD} + rb\theta^2_{ACD} + rc\theta^2_{ABD} + rd\theta^2_{ABC} + rab\theta^2_{CD} + rac\theta^2_{BD} + rad\theta^2_{BC} + rbc\theta^2_{AD}$
BC	$\sigma^2_{R/ABCD} + r\theta^2_{ABCD} + ra\theta^2_{BCD} + rb\theta^2_{ACD} + rc\theta^2_{ABD} + rd\theta^2_{ABC} + rab\theta^2_{CD} + rac\theta^2_{BD} + rad\theta^2_{BC}$
BD	$\sigma^2_{R/ABCD} + r\theta^2_{ABCD} + ra\theta^2_{BCD} + rb\theta^2_{ACD} + rc\theta^2_{ABD} + rd\theta^2_{ABC} + rab\theta^2_{CD} + rac\theta^2_{BD}$
CD	$\sigma^2_{R/ABCD} + r\theta^2_{ABCD} + ra\theta^2_{BCD} + rb\theta^2_{ACD} + rc\theta^2_{ABD} + rd\theta^2_{ABC} + rab\theta^2_{CD}$
ABC	$\sigma^2_{R/ABCD} + r\theta^2_{ABCD} + ra\theta^2_{BCD} + rb\theta^2_{ACD} + rc\theta^2_{ABD} + rd\theta^2_{ABC}$
ABD	$\sigma^2_{R/ABCD} + r\theta^2_{ABCD} + ra\theta^2_{BCD} + rb\theta^2_{ACD} + rc\theta^2_{ABD}$
ACD	$\sigma^2_{R/ABCD} + r\theta^2_{ABCD} + ra\theta^2_{BCD} + rb\theta^2_{ACD}$
BCD	$\sigma^2_{R/ABCD} + r\theta^2_{ABCD} + ra\theta^2_{BCD}$
ABCD	$\sigma^2_{R/ABCD} + r\theta^2_{ABCD}$
R/ABCD	$\sigma^2_{R/ABCD}$





B	$\sigma^2_{R/ABCD} + r\theta^2_{ABCD} + ra\theta^2_{BCD} + rb\theta^2_{ACD} + rc\theta^2_{ABD} + rd\theta^2_{ABC} + rab\theta^2_{CD} + rac\theta^2_{BD} + rad\theta^2_{BC} + rbc\theta^2_{AD} + rbd\theta^2_{AC} + rcd\theta^2_{AB} + rabc\theta^2_D + rabd\theta^2_C + racd\theta^2_B$
C	$\sigma^2_{R/ABCD} + r\theta^2_{ABCD} + ra\theta^2_{BCD} + rb\theta^2_{ACD} + rc\theta^2_{ABD} + rd\theta^2_{ABC} + rab\theta^2_{CD} + rac\theta^2_{BD} + rad\theta^2_{BC} + rbc\theta^2_{AD} + rbd\theta^2_{AC} + rcd\theta^2_{AB} + rabc\theta^2_D + rabd\theta^2_C$
D	$\sigma^2_{R/ABCD} + r\theta^2_{ABCD} + ra\theta^2_{BCD} + rb\theta^2_{ACD} + rc\theta^2_{ABD} + rd\theta^2_{ABC} + rab\theta^2_{CD} + rac\theta^2_{BD} + rad\theta^2_{BC} + rbc\theta^2_{AD} + rbd\theta^2_{AC} + rcd\theta^2_{AB} + rabc\theta^2_D$
AB	$\sigma^2_{R/ABCD} + r\theta^2_{ABCD} + ra\theta^2_{BCD} + rb\theta^2_{ACD} + rc\theta^2_{ABD} + rd\theta^2_{ABC} + rab\theta^2_{CD} + rac\theta^2_{BD} + rad\theta^2_{BC} + rbc\theta^2_{AD} + rbd\theta^2_{AC} + rcd\theta^2_{AB}$
AC	$\sigma^2_{R/ABCD} + r\theta^2_{ABCD} + ra\theta^2_{BCD} + rb\theta^2_{ACD} + rc\theta^2_{ABD} + rd\theta^2_{ABC} + rab\theta^2_{CD} + rac\theta^2_{BD} + rad\theta^2_{BC} + rbc\theta^2_{AD} + rbd\theta^2_{AC}$
AD	$\sigma^2_{R/ABCD} + r\theta^2_{ABCD} + ra\theta^2_{BCD} + rb\theta^2_{ACD} + rc\theta^2_{ABD} + rd\theta^2_{ABC} + rab\theta^2_{CD} + rac\theta^2_{BD} + rad\theta^2_{BC} + rbc\theta^2_{AD}$
BC	$\sigma^2_{R/ABCD} + r\theta^2_{ABCD} + ra\theta^2_{BCD} + rb\theta^2_{ACD} + rc\theta^2_{ABD} + rd\theta^2_{ABC} + rab\theta^2_{CD} + rac\theta^2_{BD} + rad\theta^2_{BC}$
BD	$\sigma^2_{R/ABCD} + r\theta^2_{ABCD} + ra\theta^2_{BCD} + rb\theta^2_{ACD} + rc\theta^2_{ABD} + rd\theta^2_{ABC} + rab\theta^2_{CD} + rac\theta^2_{BD}$
CD	$\sigma^2_{R/ABCD} + r\theta^2_{ABCD} + ra\theta^2_{BCD} + rb\theta^2_{ACD} + rc\theta^2_{ABD} + rd\theta^2_{ABC} + rab\theta^2_{CD}$
ABC	$\sigma^2_{R/ABCD} + r\theta^2_{ABCD} + ra\theta^2_{BCD} + rb\theta^2_{ACD} + rc\theta^2_{ABD} + rd\theta^2_{ABC}$
ABD	$\sigma^2_{R/ABCD} + r\theta^2_{ABCD} + ra\theta^2_{BCD} + rb\theta^2_{ACD} + rc\theta^2_{ABD}$
ACD	$\sigma^2_{R/ABCD} + r\theta^2_{ABCD} + ra\theta^2_{BCD} + rb\theta^2_{ACD}$
BCD	$\sigma^2_{R/ABCD} + r\theta^2_{ABCD} + ra\theta^2_{BCD}$
ABCD	$\sigma^2_{R/ABCD} + r\theta^2_{ABCD}$
R/ABCD	$\sigma^2_{R/ABCD}$

**Tabel 6 Anava model 2 (Faktor ABCD Tetap)**

SV	Df	Fhitung	Ftabel
A	a-1=1	$F_{hitung}(A) = \frac{KT(A)}{KT(R/ABCD)}$	$F_{\alpha; db(A); db(R/ABCD)}$
B	b-1=1	$F_{hitung}(B) = \frac{KT(B)}{KT(R/ABCD)}$	$F_{\alpha; db(B); db(R/ABCD)}$

SV	Df	Fhitung	Ftabel
C	c-1=1	$F_{hitung}(C) = \frac{KT(C)}{KT(R/ABCD)}$	$F_{\alpha;db(C);db(R/ABCD)}$
D	d-1=1	$F_{hitung}(D) = \frac{KT(D)}{KT(R/ABCD)}$	$F_{\alpha;db(D);db(R/ABCD)}$
AB	(a-1)(b-1)=1	$F_{hitung}(AB) = \frac{KT(AB)}{KT(R/ABCD)}$	$F_{\alpha;db(AB);db(R/ABCD)}$
AC	(a-1)(c-1)=1	$F_{hitung}(AC) = \frac{KT(AC)}{KT(R/ABCD)}$	$F_{\alpha;db(AC);db(R/ABCD)}$
AD	(a-1)(d-1)=1	$F_{hitung}(AD) = \frac{KT(AD)}{KT(R/ABCD)}$	$F_{\alpha;db(AD);db(R/ABCD)}$
BC	(b-1)(c-1)=1	$F_{hitung}(BC) = \frac{KT(BC)}{KT(R/ABCD)}$	$F_{\alpha;db(BC);db(R/ABCD)}$
BD	(b-1)(d-1)=1	$F_{hitung}(BD) = \frac{KT(BD)}{KT(R/ABCD)}$	$F_{\alpha;db(BD);db(R/ABCD)}$
CD	(c-1)(d-1)=1	$F_{hitung}(CD) = \frac{KT(CD)}{KT(R/ABCD)}$	$F_{\alpha;db(CD);db(R/ABCD)}$
ABC	(a-1)(b-1)(c-1)=1	$F_{hitung}(ABC) = \frac{KT(ABC)}{KT(R/ABCD)}$	$F_{\alpha;db(ABC);db(R/ABCD)}$
ABD	(a-1)(b-1)(d-1)=1	$F_{hitung}(ABD) = \frac{KT(ABD)}{KT(R/ABCD)}$	$F_{\alpha;db(ABD);db(R/ABCD)}$
ACD	(a-1)(c-1)(d-1)=1	$F_{hitung}(ACD) = \frac{KT(ACD)}{KT(R/ABCD)}$	$F_{\alpha;db(ACD);db(R/ABCD)}$
BCD	(b-1)(c-1)(d-1)=1	$F_{hitung}(BCD) = \frac{KT(BCD)}{KT(R/ABCD)}$	$F_{\alpha;db(BCD);db(R/ABCD)}$
ABCD	(a-1)(b-1)(c-1)(d-1)=1	$F_{hitung}(ABCD) = \frac{KT(ABCD)}{KT(R/ABCD)}$	$F_{\alpha;db(ABCD);db(R/ABCD)}$
R/ABCD	(r-1)abcd=32		

### Model 3. Faktor A B C acak & D tetap

**Tabel 7 Anava Model 3 (Faktor ABC Acak dan D Tetap)**

SV	Df	Fhitung	Ftabel
AB	(a-1)(b-1)=1	$F_{hitung}(AB) = \frac{KT(AB)}{KT(ABC)}$	$F_{\alpha;db(AB);db(ABC)}$

SV	Df	Fhitung	Ftabel
AC	$(a-1)(c-1)=1$	$F_{hitung}(AC) = \frac{KT(AC)}{KT(ABC)}$	$F_{\alpha;db(AC);db(ABC)}$
BC	$(b-1)(c-1)=1$	$F_{hitung}(BC) = \frac{KT(BC)}{KT(ABC)}$	$F_{\alpha;db(BC);db(ABC)}$
ABC	$(a-1)(b-1)(c-1)=1$	$F_{hitung}(ABC) = \frac{KT(ABC)}{KT(R/ABCD)}$	$F_{\alpha;db(ABC);db(R/ABCD)}$
ABD	$(a-1)(b-1)(d-1)=1$	$F_{hitung}(ABD) = \frac{KT(ABD)}{KT(ABCD)}$	$F_{\alpha;db(ABD);db(ABCD)}$
ACD	$(a-1)(c-1)(d-1)=1$	$F_{hitung}(ACD) = \frac{KT(ACD)}{KT(ABCD)}$	$F_{\alpha;db(ACD);db(ABCD)}$
BCD	$(b-1)(c-1)(d-1)=1$	$F_{hitung}(BCD) = \frac{KT(BCD)}{KT(ABCD)}$	$F_{\alpha;db(BCD);db(ABCD)}$
ABCD	$(a-1)(b-1)(c-1)(d-1)=1$	$F_{hitung}(ABCD) = \frac{KT(ABCD)}{KT(R/ABCD)}$	$F_{\alpha;db(ABCD);db(R/ABCD)}$
R/ABCD	$(r-1)abcd=32$		

#### Model 4. Faktor A B D acak & C tetap

**Tabel 8 Anava model 4 (Faktor ABD Acak dan C Tetap)**

SV	Df	Fhitung	Ftabel
AB	$(a-1)(b-1)=1$	$F_{hitung}(AB) = \frac{KT(AB)}{KT(ABD)}$	$F_{\alpha;db(AB);db(ABD)}$
AD	$(a-1)(d-1)=1$	$F_{hitung}(AD) = \frac{KT(AD)}{KT(ABD)}$	$F_{\alpha;db(AD);db(ABD)}$
BD	$(b-1)(d-1)=1$	$F_{hitung}(BD) = \frac{KT(BD)}{KT(ABD)}$	$F_{\alpha;db(BD);db(ABD)}$
ABC	$(a-1)(b-1)(c-1)=1$	$F_{hitung}(ABC) = \frac{KT(ABC)}{KT(ABCD)}$	$F_{\alpha;db(ABC);db(ABCD)}$
ABD	$(a-1)(b-1)(d-1)=1$	$F_{hitung}(ABD) = \frac{KT(ABD)}{KT(R/ABCD)}$	$F_{\alpha;db(ABD);db(R/ABCD)}$
ACD	$(a-1)(c-1)(d-1)=1$	$F_{hitung}(ACD) = \frac{KT(ACD)}{KT(ABCD)}$	$F_{\alpha;db(ACD);db(ABCD)}$
BCD	$(b-1)(c-1)(d-1)=1$	$F_{hitung}(BCD) = \frac{KT(BCD)}{KT(ABCD)}$	$F_{\alpha;db(BCD);db(ABCD)}$
ABCD	$(a-1)(b-1)(c-1)(d-1)=1$	$F_{hitung}(ABCD) = \frac{KT(ABCD)}{KT(R/ABCD)}$	$F_{\alpha;db(ABCD);db(R/ABCD)}$
R/ABCD	$(r-1)abcd=32$		

#### Model 5. Faktor A C D acak & B tetap

**Tabel 9 Anava Model 5 (Faktor ACD Acak dan B Tetap)**

SV	Df	Fhitung	Ftabel
AC	(a-1)(c-1)=1	$F_{hitung}(AC) = \frac{KT(AC)}{KT(ACD)}$	$F_{\alpha;db(AC);db(ACD)}$
AD	(a-1)(d-1)=1	$F_{hitung}(AD) = \frac{KT(AD)}{KT(ACD)}$	$F_{\alpha;db(AD);db(ACD)}$
CD	(c-1)(d-1)=1	$F_{hitung}(CD) = \frac{KT(CD)}{KT(ACD)}$	$F_{\alpha;db(CD);db(ACD)}$
ABC	(a-1)(b-1)(c-1)=1	$F_{hitung}(ABC) = \frac{KT(ABC)}{KT(ABCD)}$	$F_{\alpha;db(ABC);db(ABCD)}$
ABD	(a-1)(b-1)(d-1)=1	$F_{hitung}(ABD) = \frac{KT(ABD)}{KT(ABCD)}$	$F_{\alpha;db(ABD);db(ABCD)}$
ACD	(a-1)(c-1)(d-1)=1	$F_{hitung}(ACD) = \frac{KT(ACD)}{KT(R/ABCD)}$	$F_{\alpha;db(ACD);db(ABCD)}$
BCD	(b-1)(c-1)(d-1)=1	$F_{hitung}(BCD) = \frac{KT(BCD)}{KT(ABCD)}$	$F_{\alpha;db(BCD);db(ABCD)}$
ABCD	(a-1)(b-1)(c-1)(d-1)=1	$F_{hitung}(ABCD) = \frac{KT(ABCD)}{KT(R/ABCD)}$	$F_{\alpha;db(ABCD);db(R/ABCD)}$
R/ABCD	(r-1)abcd=32		

**Model 6. Faktor B C D acak & A tetap**

**Tabel 10 Anava Model 6 (Faktor BCD acak dan A Tetap)**

SV	Df	Fhitung	Ftabel
BC	(b-1)(c-1)=1	$F_{hitung}(BC) = \frac{KT(BC)}{KT(BCD)}$	$F_{\alpha;db(BC);db(BCD)}$
BD	(b-1)(d-1)=1	$F_{hitung}(BD) = \frac{KT(BD)}{KT(BCD)}$	$F_{\alpha;db(BD);db(BCD)}$
CD	(c-1)(d-1)=1	$F_{hitung}(CD) = \frac{KT(CD)}{KT(BCD)}$	$F_{\alpha;db(CD);db(BCD)}$
ABC	(a-1)(b-1)(c-1)=1	$F_{hitung}(ABC) = \frac{KT(ABC)}{KT(ABCD)}$	$F_{\alpha;db(ABC);db(ABCD)}$
ABD	(a-1)(b-1)(d-1)=1	$F_{hitung}(ABD) = \frac{KT(ABD)}{KT(ABCD)}$	$F_{\alpha;db(ABD);db(ABCD)}$
ACD	(a-1)(c-1)(d-1)=1	$F_{hitung}(ACD) = \frac{KT(ACD)}{KT(ABCD)}$	$F_{\alpha;db(ACD);db(ABCD)}$
BCD	(b-1)(c-1)(d-1)=1	$F_{hitung}(BCD) = \frac{KT(BCD)}{KT(R/ABCD)}$	$F_{\alpha;db(BCD);db(R/ABCD)}$
ABCD	(a-1)(b-1)(c-1)(d-1)=1	$F_{hitung}(ABCD) = \frac{KT(ABCD)}{KT(R/ABCD)}$	$F_{\alpha;db(ABCD);db(R/ABCD)}$
R/ABCD	(r-1)abcd=32		

**Model 7. Faktor A B Acak & C D Tetap**

**Tabel 11 Anava Model 7 (Faktor AB Acak dan CD Tetap)**

SV	Df	Fhitung	Ftabel
A	a-1=1	$F_{hitung}(A) = \frac{KT(A)}{KT(AB)}$	$F_{\alpha;db(A);db(AB)}$
B	b-1=1	$F_{hitung}(B) = \frac{KT(B)}{KT(AB)}$	$F_{\alpha;db(B);db(AB)}$
AB	(a-1)(b-1)=1	$F_{hitung}(AB) = \frac{KT(AB)}{KT(R/ABCD)}$	$F_{\alpha;db(AB);db(R/ABCD)}$
AC	(a-1)(c-1)=1	$F_{hitung}(AC) = \frac{KT(AC)}{KT(ABC)}$	$F_{\alpha;db(AC);db(ABC)}$
AD	(a-1)(d-1)=1	$F_{hitung}(AD) = \frac{KT(AD)}{KT(ABD)}$	$F_{\alpha;db(AD);db(ABD)}$
BC	(b-1)(c-1)=1	$F_{hitung}(BC) = \frac{KT(BC)}{KT(ABC)}$	$F_{\alpha;db(BC);db(ABC)}$
BD	(b-1)(d-1)=1	$F_{hitung}(BD) = \frac{KT(BD)}{KT(ABD)}$	$F_{\alpha;db(BD);db(ABD)}$
ABC	(a-1)(b-1)(c-1)=1	$F_{hitung}(ABC) = \frac{KT(ABC)}{KT(R/ABCD)}$	$F_{\alpha;db(ABC);db(R/ABCD)}$
ABD	(a-1)(b-1)(d-1)=1	$F_{hitung}(ABD) = \frac{KT(ABD)}{KT(R/ABCD)}$	$F_{\alpha;db(ABD);db(R/ABCD)}$
ACD	(a-1)(c-1)(d-1)=1	$F_{hitung}(ACD) = \frac{KT(ACD)}{KT(ABCD)}$	$F_{\alpha;db(ACD);db(ABCD)}$
BCD	(b-1)(c-1)(d-1)=1	$F_{hitung}(BCD) = \frac{KT(BCD)}{KT(ABCD)}$	$F_{\alpha;db(BCD);db(ABCD)}$
ABCD	(a-1)(b-1)(c-1)(d-1)=1	$F_{hitung}(ABCD) = \frac{KT(ABCD)}{KT(R/ABCD)}$	$F_{\alpha;db(ABCD);db(R/ABCD)}$
R/ABCD	(r-1)abcd=32		

**Model 8. Faktor A C acak & B D tetap**

**Tabel 12 Anava Model 8 (Faktor AC Acak dan BD Tetap)**

SV	Df	Fhitung	Ftabel
A	a-1=1	$F_{hitung}(A) = \frac{KT(A)}{KT(AC)}$	$F_{\alpha;db(A);db(AC)}$
C	c-1=1	$F_{hitung}(C) = \frac{KT(C)}{KT(AC)}$	$F_{\alpha;db(C);db(AC)}$

SV	Df	Fhitung	Ftabel
AB	(a-1)(b-1)=1	$F_{hitung}(AB) = \frac{KT(AB)}{KT(ABC)}$	$F_{\alpha;db(AB);db(ABC)}$
AC	(a-1)(c-1)=1	$F_{hitung}(AC) = \frac{KT(AC)}{KT(R/ABCD)}$	$F_{\alpha;db(AC);db(R/ABCD)}$
AD	(a-1)(d-1)=1	$F_{hitung}(AD) = \frac{KT(AD)}{KT(ACD)}$	$F_{\alpha;db(AD);db(ACD)}$
BC	(b-1)(c-1)=1	$F_{hitung}(BC) = \frac{KT(BC)}{KT(ABC)}$	$F_{\alpha;db(BC);db(ABC)}$
CD	(c-1)(d-1)=1	$F_{hitung}(CD) = \frac{KT(CD)}{KT(ACD)}$	$F_{\alpha;db(CD);db(ACD)}$
ABC	(a-1)(b-1)(c-1)=1	$F_{hitung}(ABC) = \frac{KT(ABC)}{KT(R/ABCD)}$	$F_{\alpha;db(ABC);db(R/ABCD)}$
ABD	(a-1)(b-1)(d-1)=1	$F_{hitung}(ABD) = \frac{KT(ABD)}{KT(ABCD)}$	$F_{\alpha;db(ABD);db(ABCD)}$
ACD	(a-1)(c-1)(d-1)=1	$F_{hitung}(ACD) = \frac{KT(ACD)}{KT(R/ABCD)}$	$F_{\alpha;db(ACD);db(R/ABCD)}$
BCD	(b-1)(c-1)(d-1)=1	$F_{hitung}(BCD) = \frac{KT(BCD)}{KT(ABCD)}$	$F_{\alpha;db(BCD);db(ABCD)}$
ABCD	(a-1)(b-1)(c-1)(d-1)=1	$F_{hitung}(ABCD) = \frac{KT(ABCD)}{KT(R/ABCD)}$	$F_{\alpha;db(ABCD);db(R/ABCD)}$
R/ABCD	(r-1)abcd=32		

### Model 9. Faktor B C acak & A D tetap

**Tabel 13 Anava Model 9 (Faktor BC Acak dan AD Tetap)**

SV	Df	Fhitung	Ftabel
B	b-1=1	$F_{hitung}(B) = \frac{KT(B)}{KT(BC)}$	$F_{\alpha;db(B);db(BC)}$
C	c-1=1	$F_{hitung}(C) = \frac{KT(C)}{KT(BC)}$	$F_{\alpha;db(C);db(BC)}$
AB	(a-1)(b-1)=1	$F_{hitung}(AB) = \frac{KT(AB)}{KT(ABC)}$	$F_{\alpha;db(AB);db(ABC)}$
AC	(a-1)(c-1)=1	$F_{hitung}(AC) = \frac{KT(AC)}{KT(ABC)}$	$F_{\alpha;db(AC);db(ABC)}$
AD	(a-1)(d-1)=1	$F_{hitung}(AD) = \frac{KT(AD)}{KT(R/ABCD)}$	$F_{\alpha;db(AD);db(R/ABCD)}$
BC	(b-1)(c-1)=1	$F_{hitung}(BC) = \frac{KT(BC)}{KT(R/ABCD)}$	$F_{\alpha;db(BC);db(R/ABCD)}$
BD	(b-1)(d-1)=1	$F_{hitung}(BD) = \frac{KT(BD)}{KT(BCD)}$	$F_{\alpha;db(BD);db(BCD)}$

SV	Df	Fhitung	Ftabel
CD	(c-1)(d-1)=1	$F_{hitung}(CD) = \frac{KT(CD)}{KT(BCD)}$	$F_{\alpha;db(CD);db(BCD)}$
ABC	(a-1)(b-1)(c-1)=1	$F_{hitung}(ABC) = \frac{KT(ABC)}{KT(R/ABCD)}$	$F_{\alpha;db(ABC);db(R/ABCD)}$
ABD	(a-1)(b-1)(d-1)=1	$F_{hitung}(ABD) = \frac{KT(ABD)}{KT(ABCD)}$	$F_{\alpha;db(ABD);db(ABCD)}$
ACD	(a-1)(c-1)(d-1)=1	$F_{hitung}(ACD) = \frac{KT(ACD)}{KT(ABCD)}$	$F_{\alpha;db(ACD);db(ABCD)}$
BCD	(b-1)(c-1)(d-1)=1	$F_{hitung}(BCD) = \frac{KT(BCD)}{KT(R/ABCD)}$	$F_{\alpha;db(BCD);db(R/ABCD)}$
ABCD	(a-1)(b-1)(c-1)(d-1)=1	$F_{hitung}(ABCD) = \frac{KT(ABCD)}{KT(R/ABCD)}$	$F_{\alpha;db(ABCD);db(R/ABCD)}$
R/ABCD	(r-1)abcd=32		

### Model 10. Faktor A D acak & B C tetap

**Tabel 14 Anava Model 10 (Faktor AD Acak dan BC Tetap)**

SV	Df	Fhitung	Ftabel
A	a-1=1	$F_{hitung}(A) = \frac{KT(A)}{KT(AD)}$	$F_{\alpha;db(A);db(AD)}$
D	d-1=1	$F_{hitung}(D) = \frac{KT(D)}{KT(AD)}$	$F_{\alpha;db(D);db(AD)}$
AB	(a-1)(b-1)=1	$F_{hitung}(AB) = \frac{KT(AB)}{KT(ABD)}$	$F_{\alpha;db(AB);db(ABD)}$
AC	(a-1)(c-1)=1	$F_{hitung}(AC) = \frac{KT(AC)}{KT(ACD)}$	$F_{\alpha;db(AC);db(ACD)}$
AD	(a-1)(d-1)=1	$F_{hitung}(AD) = \frac{KT(AD)}{KT(R/ABCD)}$	$F_{\alpha;db(AD);db(R/ABCD)}$
BD	(b-1)(d-1)=1	$F_{hitung}(BD) = \frac{KT(BD)}{KT(ABD)}$	$F_{\alpha;db(BD);db(ABD)}$
CD	(c-1)(d-1)=1	$F_{hitung}(CD) = \frac{KT(CD)}{KT(ACD)}$	$F_{\alpha;db(CD);db(ACD)}$
ABC	(a-1)(b-1)(c-1)=1	$F_{hitung}(ABC) = \frac{KT(ABC)}{KT(ABCD)}$	$F_{\alpha;db(ABC);db(ABCD)}$
ABD	(a-1)(b-1)(d-1)=1	$F_{hitung}(ABD) = \frac{KT(ABD)}{KT(R/ABCD)}$	$F_{\alpha;db(ABD);db(R/ABCD)}$
ACD	(a-1)(c-1)(d-1)=1	$F_{hitung}(ACD) = \frac{KT(ACD)}{KT(R/ABCD)}$	$F_{\alpha;db(ACD);db(R/ABCD)}$
BCD	(b-1)(c-1)(d-1)=1	$F_{hitung}(BCD) = \frac{KT(BCD)}{KT(ABCD)}$	$F_{\alpha;db(BCD);db(ABCD)}$



SV	Df	Fhitung	Ftabel
ABCD	$(a-1)(b-1)(c-1)(d-1)=1$	$F_{hitung}(ABCD) = \frac{KT(ABCD)}{KT(R/ABCD)}$	$F_{\alpha;db(ABCD);db(R/ABCD)}$
R/ABCD	$(r-1)abcd=32$		

### Model 11. Faktor B D acak & A C tetap

**Tabel 15 Anava Model 11 (Faktor BD Acak dan AC Tetap)**

SV	Df	Fhitung	Ftabel
B	$b-1=1$	$F_{hitung}(B) = \frac{KT(B)}{KT(BD)}$	$F_{\alpha;db(B);db(BD)}$
D	$d-1=1$	$F_{hitung}(D) = \frac{KT(D)}{KT(BD)}$	$F_{\alpha;db(D);db(BD)}$
AB	$(a-1)(b-1)=1$	$F_{hitung}(AB) = \frac{KT(AB)}{KT(ABD)}$	$F_{\alpha;db(AB);db(ABD)}$
AD	$(a-1)(d-1)=1$	$F_{hitung}(AD) = \frac{KT(AD)}{KT(ABD)}$	$F_{\alpha;db(AD);db(ABD)}$
BC	$(b-1)(c-1)=1$	$F_{hitung}(BC) = \frac{KT(BC)}{KT(BCD)}$	$F_{\alpha;db(BC);db(BCD)}$
BD	$(b-1)(d-1)=1$	$F_{hitung}(BD) = \frac{KT(BD)}{KT(R/ABCD)}$	$F_{\alpha;db(BD);db(R/ABCD)}$
CD	$(c-1)(d-1)=1$	$F_{hitung}(CD) = \frac{KT(CD)}{KT(BCD)}$	$F_{\alpha;db(CD);db(BCD)}$
ABC	$(a-1)(b-1)(c-1)=1$	$F_{hitung}(ABC) = \frac{KT(ABC)}{KT(ABCD)}$	$F_{\alpha;db(ABC);db(ABCD)}$
ABD	$(a-1)(b-1)(d-1)=1$	$F_{hitung}(ABD) = \frac{KT(ABD)}{KT(R/ABCD)}$	$F_{\alpha;db(ABD);db(R/ABCD)}$
ACD	$(a-1)(c-1)(d-1)=1$	$F_{hitung}(ACD) = \frac{KT(ACD)}{KT(ABCD)}$	$F_{\alpha;db(ACD);db(ABCD)}$
BCD	$(b-1)(c-1)(d-1)=1$	$F_{hitung}(BCD) = \frac{KT(BCD)}{KT(R/ABCD)}$	$F_{\alpha;db(BCD);db(R/ABCD)}$
ABCD	$(a-1)(b-1)(c-1)(d-1)=1$	$F_{hitung}(ABCD) = \frac{KT(ABCD)}{KT(R/ABCD)}$	$F_{\alpha;db(ABCD);db(R/ABCD)}$
R/ABCD	$(r-1)abcd=32$		

### Model 12. Faktor C D Acak & A B Tetap

**Tabel 16 Anava Model 12 (Faktor CD Acak dan AB Tetap)**

SV	Df	Fhitung	Ftabel
C	$c-1=1$	$F_{hitung}(C) = \frac{KT(C)}{KT(CD)}$	$F_{\alpha;db(C);db(CD)}$

SV	Df	Fhitung	Ftabel
D	d-1=1	$F_{hitung}(D) = \frac{KT(D)}{KT(CD)}$	$F_{\alpha;db(D);db(CD)}$
AC	(a-1)(c-1)=1	$F_{hitung}(AC) = \frac{KT(AC)}{KT(ACD)}$	$F_{\alpha;db(AC);db(ACD)}$
AD	(a-1)(d-1)=1	$F_{hitung}(AD) = \frac{KT(AD)}{KT(ACD)}$	$F_{\alpha;db(AD);db(ACD)}$
BC	(b-1)(c-1)=1	$F_{hitung}(BC) = \frac{KT(BC)}{KT(BCD)}$	$F_{\alpha;db(BC);db(BCD)}$
BD	(b-1)(d-1)=1	$F_{hitung}(BD) = \frac{KT(BD)}{KT(BCD)}$	$F_{\alpha;db(BD);db(BCD)}$
CD	(c-1)(d-1)=1	$F_{hitung}(CD) = \frac{KT(CD)}{KT(R/ABCD)}$	$F_{\alpha;db(CD);db(R/ABCD)}$
ABC	(a-1)(b-1)(c-1)=1	$F_{hitung}(ABC) = \frac{KT(ABC)}{KT(ABCD)}$	$F_{\alpha;db(ABC);db(ABCD)}$
ABD	(a-1)(b-1)(d-1)=1	$F_{hitung}(ABD) = \frac{KT(ABD)}{KT(ABCD)}$	$F_{\alpha;db(ABD);db(ABCD)}$
ACD	(a-1)(c-1)(d-1)=1	$F_{hitung}(ACD) = \frac{KT(ACD)}{KT(R/ABCD)}$	$F_{\alpha;db(ACD);db(R/ABCD)}$
BCD	(b-1)(c-1)(d-1)=1	$F_{hitung}(BCD) = \frac{KT(BCD)}{KT(R/ABCD)}$	$F_{\alpha;db(BCD);db(R/ABCD)}$
ABCD	(a-1)(b-1)(c-1)(d-1)=1	$F_{hitung}(ABCD) = \frac{KT(ABCD)}{KT(R/ABCD)}$	$F_{\alpha;db(ABCD);db(R/ABCD)}$
R/ABCD	(r-1)abcd=32		

### Model 13. Faktor A acak & B C D tetap

**Tabel 17 Anava Model 13 (Faktor CD Acak dan AB Tetap)**

SV	Df	Fhitung	Ftabel
A	a-1=1	$F_{hitung}(A) = \frac{KT(A)}{KT(R/ABCD)}$	$F_{\alpha;db(A);db(R/ABCD)}$
B	b-1=1	$F_{hitung}(B) = \frac{KT(B)}{KT(AB)}$	$F_{\alpha;db(B);db(AB)}$
C	c-1=1	$F_{hitung}(C) = \frac{KT(C)}{KT(AC)}$	$F_{\alpha;db(C);db(AC)}$
D	d-1=1	$F_{hitung}(D) = \frac{KT(D)}{KT(AD)}$	$F_{\alpha;db(D);db(AD)}$
AB	(a-1)(b-1)=1	$F_{hitung}(AB) = \frac{KT(AB)}{KT(R/ABCD)}$	$F_{\alpha;db(AB);db(R/ABCD)}$
AC	(a-1)(c-1)=1	$F_{hitung}(AC) = \frac{KT(AC)}{KT(R/ABCD)}$	$F_{\alpha;db(AC);db(R/ABCD)}$

SV	Df	Fhitung	Ftabel
AD	$(a-1)(d-1)=1$	$F_{hitung}(AD) = \frac{KT(AD)}{KT(R/ABCD)}$	$F_{\alpha;db(AD);db(R/ABCD)}$
BC	$(b-1)(c-1)=1$	$F_{hitung}(BC) = \frac{KT(BC)}{KT(ABC)}$	$F_{\alpha;db(BC);db(ABC)}$
BD	$(b-1)(d-1)=1$	$F_{hitung}(BD) = \frac{KT(BD)}{KT(ABD)}$	$F_{\alpha;db(BD);db(ABD)}$
CD	$(c-1)(d-1)=1$	$F_{hitung}(CD) = \frac{KT(CD)}{KT(ACD)}$	$F_{\alpha;db(CD);db(ACD)}$
ABC	$(a-1)(b-1)(c-1)=1$	$F_{hitung}(ABC) = \frac{KT(ABC)}{KT(R/ABCD)}$	$F_{\alpha;db(ABC);db(R/ABCD)}$
ABD	$(a-1)(b-1)(d-1)=1$	$F_{hitung}(ABD) = \frac{KT(ABD)}{KT(R/ABCD)}$	$F_{\alpha;db(ABD);db(R/ABCD)}$
ACD	$(a-1)(c-1)(d-1)=1$	$F_{hitung}(ACD) = \frac{KT(ACD)}{KT(R/ABCD)}$	$F_{\alpha;db(ACD);db(R/ABCD)}$
BCD	$(b-1)(c-1)(d-1)=1$	$F_{hitung}(BCD) = \frac{KT(BCD)}{KT(R/ABCD)}$	$F_{\alpha;db(BCD);db(R/ABCD)}$
ABCD	$(a-1)(b-1)(c-1)(d-1)=1$	$F_{hitung}(ABCD) = \frac{KT(ABCD)}{KT(R/ABCD)}$	$F_{\alpha;db(ABCD);db(R/ABCD)}$
R/ABCD	$(r-1)abcd=32$		

#### Model 14. Faktor B Acak & A C D tetap

**Tabel 18 Anava Model 14 (Faktor B acak & A C D tetap)**

SV	Df	Fhitung	Ftabel
A	$a-1=1$	$F_{hitung}(A) = \frac{KT(A)}{KT(AB)}$	$F_{\alpha;db(A);db(AB)}$
B	$b-1=1$	$F_{hitung}(B) = \frac{KT(B)}{KT(R/ABCD)}$	$F_{\alpha;db(B);db(R/ABCD)}$
C	$c-1=1$	$F_{hitung}(C) = \frac{KT(C)}{KT(BC)}$	$F_{\alpha;db(C);db(BC)}$
D	$d-1=1$	$F_{hitung}(D) = \frac{KT(D)}{KT(BD)}$	$F_{\alpha;db(D);db(BD)}$
AB	$(a-1)(b-1)=1$	$F_{hitung}(AB) = \frac{KT(AB)}{KT(R/ABCD)}$	$F_{\alpha;db(AB);db(R/ABCD)}$
AC	$(a-1)(c-1)=1$	$F_{hitung}(AC) = \frac{KT(AC)}{KT(ABC)}$	$F_{\alpha;db(AC);db(ABC)}$
AD	$(a-1)(d-1)=1$	$F_{hitung}(AD) = \frac{KT(AD)}{KT(ABD)}$	$F_{\alpha;db(AD);db(ABD)}$
BC	$(b-1)(c-1)=1$	$F_{hitung}(BC) = \frac{KT(BC)}{KT(R/ABCD)}$	$F_{\alpha;db(BC);db(R/ABCD)}$

SV	Df	Fhitung	Ftabel
BD	$(b-1)(d-1)=1$	$F_{hitung}(BD) = \frac{KT(BD)}{KT(R/ABCD)}$	$F_{\alpha;db(BD);db(R/ABCD)}$
CD	$(c-1)(d-1)=1$	$F_{hitung}(CD) = \frac{KT(CD)}{KT(BCD)}$	$F_{\alpha;db(CD);db(BCD)}$
ABC	$(a-1)(b-1)(c-1)=1$	$F_{hitung}(ABC) = \frac{KT(ABC)}{KT(R/ABCD)}$	$F_{\alpha;db(ABC);db(R/ABCD)}$
ABD	$(a-1)(b-1)(d-1)=1$	$F_{hitung}(ABD) = \frac{KT(ABD)}{KT(R/ABCD)}$	$F_{\alpha;db(ABD);db(R/ABCD)}$
ACD	$(a-1)(c-1)(d-1)=1$	$F_{hitung}(ACD) = \frac{KT(ACD)}{KT(ABCD)}$	$F_{\alpha;db(ACD);db(ABCD)}$
BCD	$(b-1)(c-1)(d-1)=1$	$F_{hitung}(BCD) = \frac{KT(BCD)}{KT(R/ABCD)}$	$F_{\alpha;db(BCD);db(R/ABCD)}$
ABCD	$(a-1)(b-1)(c-1)(d-1)=1$	$F_{hitung}(ABCD) = \frac{KT(ABCD)}{KT(R/ABCD)}$	$F_{\alpha;db(ABCD);db(R/ABCD)}$
R/ABCD	$(r-1)abcd=32$		

### Model 15. Faktor C acak & A B D tetap

**Tabel 19 Anava Model 15 (Faktor C Acak & A B D tetap)**

SV	Df	Fhitung	Ftabel
A	$a-1=1$	$F_{hitung}(A) = \frac{KT(A)}{KT(AC)}$	$F_{\alpha;db(A);db(AC)}$
B	$b-1=1$	$F_{hitung}(B) = \frac{KT(B)}{KT(BC)}$	$F_{\alpha;db(B);db(BC)}$
C	$c-1=1$	$F_{hitung}(C) = \frac{KT(C)}{KT(R/ABCD)}$	$F_{\alpha;db(C);db(R/ABCD)}$
D	$d-1=1$	$F_{hitung}(D) = \frac{KT(D)}{KT(CD)}$	$F_{\alpha;db(D);db(CD)}$
AB	$(a-1)(b-1)=1$	$F_{hitung}(AB) = \frac{KT(AB)}{KT(ABC)}$	$F_{\alpha;db(AB);db(ABC)}$
AC	$(a-1)(c-1)=1$	$F_{hitung}(AC) = \frac{KT(AC)}{KT(R/ABCD)}$	$F_{\alpha;db(AC);db(R/ABCD)}$
AD	$(a-1)(d-1)=1$	$F_{hitung}(AD) = \frac{KT(AD)}{KT(ACD)}$	$F_{\alpha;db(AD);db(ACD)}$
BC	$(b-1)(c-1)=1$	$F_{hitung}(BC) = \frac{KT(BC)}{KT(R/ABCD)}$	$F_{\alpha;db(BC);db(R/ABCD)}$
BD	$(b-1)(d-1)=1$	$F_{hitung}(BD) = \frac{KT(BD)}{KT(BCD)}$	$F_{\alpha;db(BD);db(BCD)}$
CD	$(c-1)(d-1)=1$	$F_{hitung}(CD) = \frac{KT(CD)}{KT(R/ABCD)}$	$F_{\alpha;db(CD);db(R/ABCD)}$

SV	Df	Fhitung	Ftabel
ABC	$(a-1)(b-1)(c-1)=1$	$F_{hitung}(ABC) = \frac{KT(ABC)}{KT(R/ABCD)}$	$F_{\alpha;db(ABC);db(R/ABCD)}$
ABD	$(a-1)(b-1)(d-1)=1$	$F_{hitung}(ABD) = \frac{KT(ABD)}{KT(ABCD)}$	$F_{\alpha;db(ABD);db(ABCD)}$
ACD	$(a-1)(c-1)(d-1)=1$	$F_{hitung}(ACD) = \frac{KT(ACD)}{KT(R/ABCD)}$	$F_{\alpha;db(ACD);db(R/ABCD)}$
BCD	$(b-1)(c-1)(d-1)=1$	$F_{hitung}(BCD) = \frac{KT(BCD)}{KT(R/ABCD)}$	$F_{\alpha;db(BCD);db(R/ABCD)}$
ABCD	$(a-1)(b-1)(c-1)(d-1)=1$	$F_{hitung}(ABCD) = \frac{KT(ABCD)}{KT(R/ABCD)}$	$F_{\alpha;db(ABCD);db(R/ABCD)}$
R/ABCD	$(r-1)abcd=32$		

### Model 16. Faktor D Acak & A B C tetap

**Tabel 20 Anava Model 16 (Faktor D acak & A B C tetap)**

SV	Df	Fhitung	Ftabel
A	$a-1=1$	$F_{hitung}(A) = \frac{KT(A)}{KT(AD)}$	$F_{\alpha;db(A);db(AD)}$
B	$b-1=1$	$F_{hitung}(B) = \frac{KT(B)}{KT(BD)}$	$F_{\alpha;db(B);db(BD)}$
C	$c-1=1$	$F_{hitung}(C) = \frac{KT(C)}{KT(CD)}$	$F_{\alpha;db(C);db(CD)}$
D	$d-1=1$	$F_{hitung}(D) = \frac{KT(D)}{KT(R/ABCD)}$	$F_{\alpha;db(D);db(R/ABCD)}$
AB	$(a-1)(b-1)=1$	$F_{hitung}(AB) = \frac{KT(AB)}{KT(ABD)}$	$F_{\alpha;db(AB);db(ABD)}$
AC	$(a-1)(c-1)=1$	$F_{hitung}(AC) = \frac{KT(AC)}{KT(ACD)}$	$F_{\alpha;db(AC);db(ACD)}$
AD	$(a-1)(d-1)=1$	$F_{hitung}(AD) = \frac{KT(AD)}{KT(R/ABCD)}$	$F_{\alpha;db(AD);db(R/ABCD)}$
BC	$(b-1)(c-1)=1$	$F_{hitung}(BC) = \frac{KT(BC)}{KT(BCD)}$	$F_{\alpha;db(BC);db(BCD)}$
BD	$(b-1)(d-1)=1$	$F_{hitung}(BD) = \frac{KT(BD)}{KT(R/ABCD)}$	$F_{\alpha;db(BD);db(R/ABCD)}$
CD	$(c-1)(d-1)=1$	$F_{hitung}(CD) = \frac{KT(CD)}{KT(R/ABCD)}$	$F_{\alpha;db(CD);db(R/ABCD)}$
ABC	$(a-1)(b-1)(c-1)=1$	$F_{hitung}(ABC) = \frac{KT(ABC)}{KT(ABCD)}$	$F_{\alpha;db(ABC);db(ABCD)}$
ABD	$(a-1)(b-1)(d-1)=1$	$F_{hitung}(ABD) = \frac{KT(ABD)}{KT(R/ABCD)}$	$F_{\alpha;db(ABD);db(R/ABCD)}$
ACD	$(a-1)(c-1)(d-1)=1$	$F_{hitung}(ACD) = \frac{KT(ACD)}{KT(R/ABCD)}$	$F_{\alpha;db(ACD);db(R/ABCD)}$
BCD	$(b-1)(c-1)(d-1)=1$	$F_{hitung}(BCD) = \frac{KT(BCD)}{KT(R/ABCD)}$	$F_{\alpha;db(BCD);db(R/ABCD)}$

<b>SV</b>	<b>Df</b>	<b>Fhitung</b>	<b>Ftabel</b>
ABCD	$(a-1)(b-1)(c-1)(d-1)=1$	$F_{hitung}(ABCD) = \frac{KT(ABCD)}{KT(R/ABCD)}$	$F_{\alpha;db(ABCD);db(R/ABCD)}$
R/ABCD	$(r-1)abcd=32$		

## BAB IV

### DIAGRAM BLOK UNTUK SEMUA FAKTOR UTAMA INTERAKSI DAN TERDAPAT *REPEATED MEASUREMENT*

Tipe diagram blok pada bagian ini lebih banyak kemungkinannya dari pada model diagram blok pada BAB III. Hal ini karena pengaruh kondisi R, di mana banyak model diagram blok yang mungkin terjadi maka mengakibatkan ditemukan sumber variansi yang lebih banyak lagi. Model-model diagram bloknya antara lain dijelaskan berikut ini:

**Tabel 21 Diagram Blok Model 1 Faktor Utama Interaksi dan Terdapat *Repeated Measurement***

		A1		A2	
		B1	B2	B1	B2
C1	D1	R1-R3	R1-R3	R1-R3	R1-R3
	D2	R4-R6	R4-R6	R4-R6	R4-R6
C2	D1	R7-R9	R7-R9	R7-R9	R7-R9
	D2	R10-R12	R10-R12	R10-R12	R10-R12

**Tabel 22 Diagram Blok Model 2**

		A1		A2	
		B1	B2	B1	B2
C1	D1	R1-R3	R13-R15	R1-R3	R13-R15
	D2	R4-R6	R16-R18	R4-R6	R16-R18
C2	D1	R7-R9	R19-R21	R7-R9	R19-R21
	D2	R10-R12	R22-R24	R10-R12	R22-R24

**Tabel 23 Diagram Blok Model 3**

		A1		A2	
		B1	B2	B1	B2
C1	D1	R1-R3	R1-R3	R13-R15	R13-R15
	D2	R4-R6	R4-R6	R16-R18	R16-R18
C2	D1	R7-R9	R7-R9	R19-R21	R19-R21
	D2	R10-R12	R10-R12	R22-R24	R22-R24

**Tabel 24 Diagram Blok Model 4**

		<b>A1</b>		<b>A2</b>	
		<b>B1</b>	<b>B2</b>	<b>B1</b>	<b>B2</b>
<b>C1</b>	<b>D1</b>	R1-R3	R4-R6	R7-R9	R10-R12
	<b>D2</b>	R1-R3	R4-R6	R7-R9	R10-R12
<b>C2</b>	<b>D1</b>	R1-R3	R4-R6	R7-R9	R10-R12
	<b>D2</b>	R1-R3	R4-R6	R7-R9	R10-R12

**Tabel 25 Diagram Blok Model 5**

		<b>A1</b>		<b>A2</b>	
		<b>B1</b>	<b>B2</b>	<b>B1</b>	<b>B2</b>
<b>C1</b>	<b>D1</b>	R1-R3	R4-R6	R7-R9	R10-R12
	<b>D2</b>	R13-R15	R16-R18	R19-R21	R22-R24
<b>C2</b>	<b>D1</b>	R1-R3	R4-R6	R7-R9	R10-R12
	<b>D2</b>	R13-R15	R16-R18	R19-R21	R22-R24

**Tabel 26 Diagram Blok Model 6**

		<b>A1</b>		<b>A2</b>	
		<b>B1</b>	<b>B2</b>	<b>B1</b>	<b>B2</b>
<b>C1</b>	<b>D1</b>	R1-R3	R4-R6	R7-R9	R10-R12
	<b>D2</b>	R1-R3	R4-R6	R7-R9	R10-R12
<b>C2</b>	<b>D1</b>	R13-R15	R16-R18	R19-R21	R22-R24
	<b>D2</b>	R13-R15	R16-R18	R19-R21	R22-R24

Pada Bab III penulis menentukan 6 model diagram blok yang berbeda. Dari keenam diagram blok tersebut menghasilkan SV yang berbeda pula. Di bawah ini akan diberikan langkah-langkah penentuan SV untuk semua model tersebut. Silahkan pembaca cermati untuk pengembangan selanjutnya.



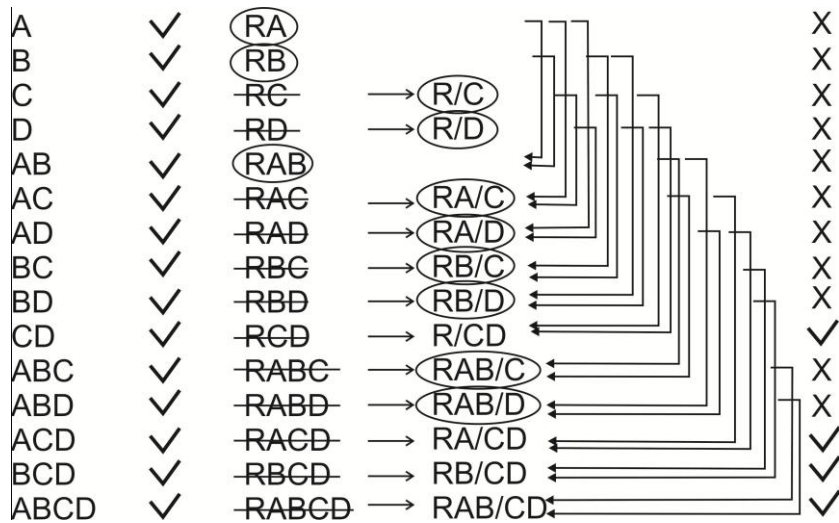

**Gambar 2 Menentukan Sumber Variansi Model 1 Faktor Utama Interaksi dan Terdapat *Repeated Measurement***

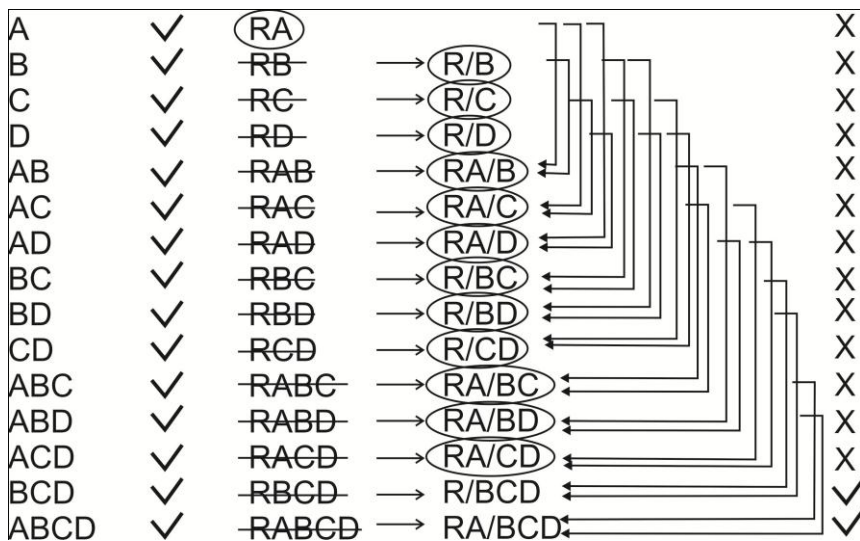

**Gambar 3 Menentukan Sumber Variansi Model 2**

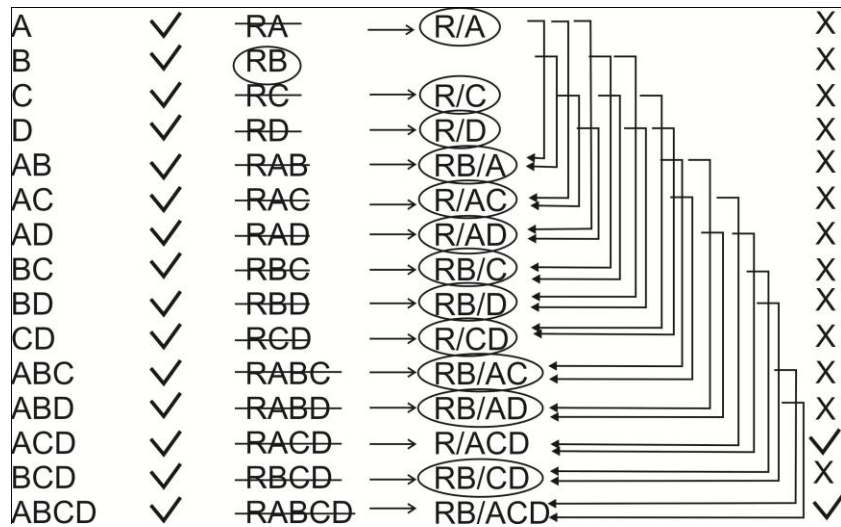

**Gambar 4 Menentukan Sumber Variansi Model 3**

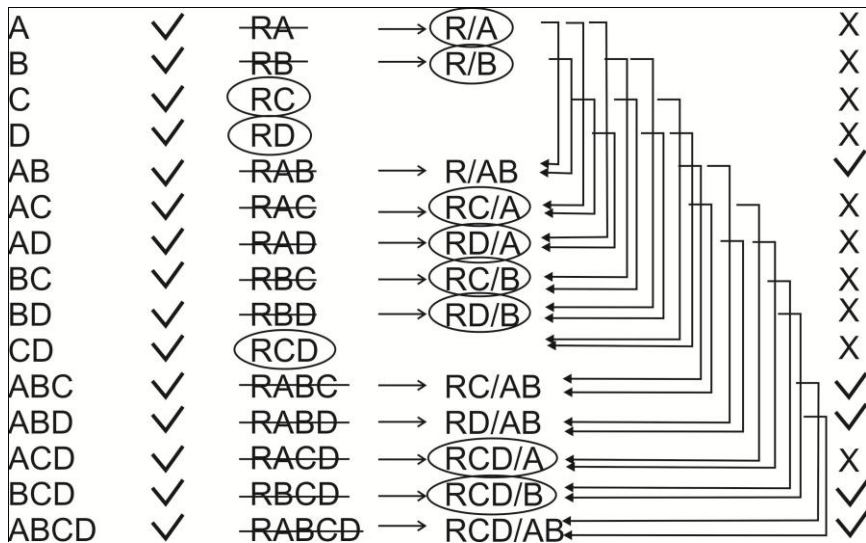

**Gambar 5 Menentukan Sumber Variansi Model 4**

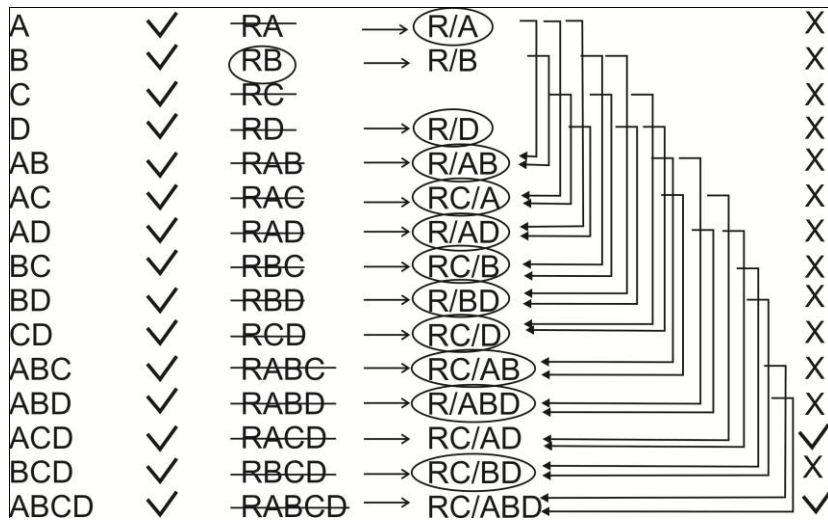

**Gambar 6 Menentukan Sumber Variansi Model 5**

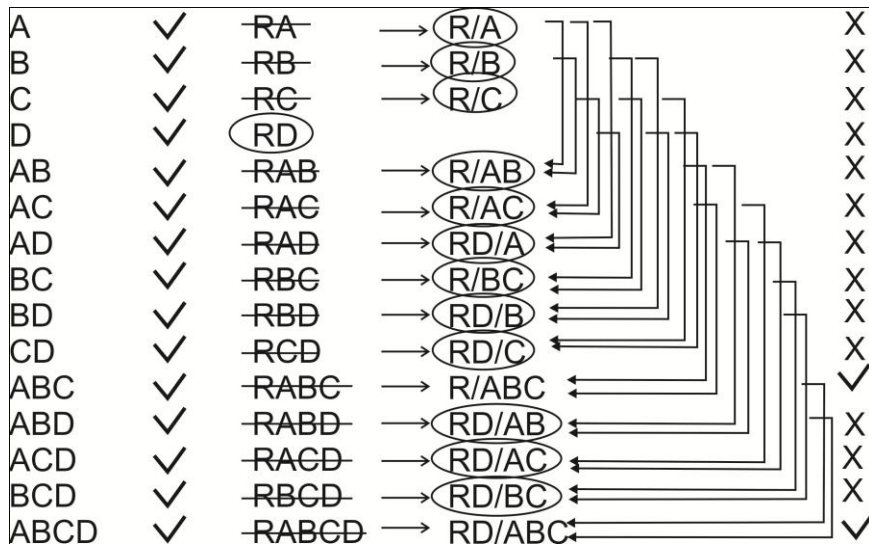

**Gambar 7 Menentukan Sumber Variansi Model 6**

Setiap model diagram blok akan menghasilkan 16 model tabel ANAVA. Adapun kombinasinya adalah sebagai berikut:

**Tabel 27 Berbagai Kemungkinan Tabel Anava Faktor Utama Interaksi dan Terdapat *Repeated Measurement***

	Faktor A	Faktor B	Faktor C	Faktor D
Model 1	A	A	A	A
Model 2	T	T	T	T
Model 3	A	A	A	T
Model 4	A	A	T	A
Model 5	A	T	A	A
Model 6	T	A	A	A
Model 7	A	A	T	T
Model 8	A	T	A	T
Model 9	T	A	A	T
Model 10	A	T	T	A
Model 11	T	A	T	A
Model 12	T	A	A	T
Model 13	A	T	T	T
Model 14	T	A	T	T
Model 15	T	T	A	T
Model 16	T	T	T	A

Keterangan :

A : Acak

T : Tetap

Sehingga untuk kasus ini kemungkinan bisa ditemukan  $6 \times 16 = 96$  model tabel ANAVA. Akan tetapi, kali ini hanya akan ditentukan berbagai model tabel ANAVA untuk model diagram blok yang pertama. Selebihnya bisa dicoba dicari sendiri oleh para pembaca.

Menentukan tabel ANAVA untuk model tabel ANAVA yang pertama

**Model 1. Faktor A B C D semua acak**

Tahapan Menentukan SV

langkah pertama

SV	EMS
A	$\sigma^2_{RAB/CD} + a\sigma^2_{RB/CD} + b\sigma^2_{RA/CD} + ab\sigma^2_{R/CD} + r\sigma^2_{ABCD} + ra\sigma^2_{BCD} + rb\sigma^2_{ACD} + rc\sigma^2_{ABD} + rd\sigma^2_{ABC} + rab\sigma^2_{CD} + rac\sigma^2_{BD} + rad\sigma^2_{BC} + rbc$





ABC	$(a-1)(b-1)(c-1)=1$	$F_{hitung}(ABC) = \frac{KT(ABC)}{KT(ABCD)}$	$F_{\alpha;db(ABC);db(ABCD)}$
ABD	$(a-1)(b-1)(d-1)=1$	$F_{hitung}(ABD) = \frac{KT(ABD)}{KT(ABCD)}$	$F_{\alpha;db(ABD);db(ABCD)}$
ABCD	$(a-1)(b-1)(c-1)(d-1)=1$	$F_{hitung}(ABCD) = \frac{KT(ABCD)}{KT(RAB/CD)}$	$F_{\alpha;db(ABCD);db(RAB/CD)}$

## Model 2. Faktor A B C D semua Tetap

### Menentukan SV

Langkah pertama

SV	EMS
A	$\sigma^2_{RAB/CD} + a\sigma^2_{RB/CD} + b\sigma^2_{RA/CD} + ab\sigma^2_{R/CD} + r\theta^2_{ABCD} + ra\theta^2_{BCD} + rb\theta^2_{ACD} + rc\theta^2_{ABD} + rd\theta^2_{ABC} + rab\theta^2_{CD} + rac\theta^2_{BD} + rad\theta^2_{BC} + rbc\theta^2_{AD} + rbd\theta^2_{AC} + rcd\theta^2_{AB} + rabc\theta^2_{D} + rabd\theta^2_{C} + racd\theta^2_{B} + rbcd\theta^2_{A}$
B	$\sigma^2_{RAB/CD} + a\sigma^2_{RB/CD} + b\sigma^2_{RA/CD} + ab\sigma^2_{R/CD} + r\theta^2_{ABCD} + ra\theta^2_{BCD} + rb\theta^2_{ACD} + rc\theta^2_{ABD} + rd\theta^2_{ABC} + rab\theta^2_{CD} + rac\theta^2_{BD} + rad\theta^2_{BC} + rbc\theta^2_{AD} + rbd\theta^2_{AC} + rcd\theta^2_{AB} + rabc\theta^2_{D} + rabd\theta^2_{C} + racd\theta^2_{B}$
C	$\sigma^2_{RAB/CD} + a\sigma^2_{RB/CD} + b\sigma^2_{RA/CD} + ab\sigma^2_{R/CD} + r\theta^2_{ABCD} + ra\theta^2_{BCD} + rb\theta^2_{ACD} + rc\theta^2_{ABD} + rd\theta^2_{ABC} + rab\theta^2_{CD} + rac\theta^2_{BD} + rad\theta^2_{BC} + rbc\theta^2_{AD} + rbd\theta^2_{AC} + rcd\theta^2_{AB} + rabc\theta^2_{D} + rabd\theta^2_{C}$
D	$\sigma^2_{RAB/CD} + a\sigma^2_{RB/CD} + b\sigma^2_{RA/CD} + ab\sigma^2_{R/CD} + r\theta^2_{ABCD} + ra\theta^2_{BCD} + rb\theta^2_{ACD} + rc\theta^2_{ABD} + rd\theta^2_{ABC} + rab\theta^2_{CD} + rac\theta^2_{BD} + rad\theta^2_{BC} + rbc\theta^2_{AD} + rbd\theta^2_{AC} + rcd\theta^2_{AB} + rabc\theta^2_{D}$
AB	$\sigma^2_{RAB/CD} + a\sigma^2_{RB/CD} + b\sigma^2_{RA/CD} + ab\sigma^2_{R/CD} + r\theta^2_{ABCD} + ra\theta^2_{BCD} + rb\theta^2_{ACD} + rc\theta^2_{ABD} + rd\theta^2_{ABC} + rab\theta^2_{CD} + rac\theta^2_{BD} + rad\theta^2_{BC} + rbc\theta^2_{AD} + rbd\theta^2_{AC} + rcd\theta^2_{AB}$
AC	$\sigma^2_{RAB/CD} + a\sigma^2_{RB/CD} + b\sigma^2_{RA/CD} + ab\sigma^2_{R/CD} + r\theta^2_{ABCD} + ra\theta^2_{BCD} + rb\theta^2_{ACD} + rc\theta^2_{ABD} + rd\theta^2_{ABC} + rab\theta^2_{CD} + rac\theta^2_{BD} + rad\theta^2_{BC} + rbc\theta^2_{AD} + rbd\theta^2_{AC}$
AD	$\sigma^2_{RAB/CD} + a\sigma^2_{RB/CD} + b\sigma^2_{RA/CD} + ab\sigma^2_{R/CD} + r\theta^2_{ABCD} + ra\theta^2_{BCD} + rb\theta^2_{ACD} + rc\theta^2_{ABD} + rd\theta^2_{ABC} + rab\theta^2_{CD} + rac\theta^2_{BD} + rad\theta^2_{BC} + rbc\theta^2_{AD} + rbd\theta^2_{AC}$
BC	$\sigma^2_{RAB/CD} + a\sigma^2_{RB/CD} + b\sigma^2_{RA/CD} + ab\sigma^2_{R/CD} + r\theta^2_{ABCD} + ra\theta^2_{BCD} + rb\theta^2_{ACD} + rc\theta^2_{ABD} + rd\theta^2_{ABC} + rab\theta^2_{CD} + rac\theta^2_{BD} + rad\theta^2_{BC}$
BD	$\sigma^2_{RAB/CD} + a\sigma^2_{RB/CD} + b\sigma^2_{RA/CD} + ab\sigma^2_{R/CD} + r\theta^2_{ABCD} + ra\theta^2_{BCD} + rb\theta^2_{ACD} + rc\theta^2_{ABD} + rd\theta^2_{ABC} + rab\theta^2_{CD} + rac\theta^2_{BD}$





SV	EMS
BD	$\sigma^2_{RAB/CD} + a\sigma^2_{RB/CD} + b\sigma^2_{RA/CD} + ab\sigma^2_{R/CD} + r\theta^2_{ABCD} + ra\theta^2_{BCD} + rb\theta^2_{ACD} + rc\theta^2_{ABD} + rd\theta^2_{ABC} + rab\theta^2_{CD} + rac\theta^2_{BD}$
CD	$\sigma^2_{RAB/CD} + a\sigma^2_{RB/CD} + b\sigma^2_{RA/CD} + ab\sigma^2_{R/CD} + r\theta^2_{ABCD} + ra\theta^2_{BCD} + rb\theta^2_{ACD} + rc\theta^2_{ABD} + rd\theta^2_{ABC} + rab\theta^2_{CD}$
ABC	$\sigma^2_{RAB/CD} + a\sigma^2_{RB/CD} + b\sigma^2_{RA/CD} + ab\sigma^2_{R/CD} + r\theta^2_{ABCD} + ra\theta^2_{BCD} + rb\theta^2_{ACD} + rc\theta^2_{ABD} + rd\theta^2_{ABC}$
ABD	$\sigma^2_{RAB/CD} + a\sigma^2_{RB/CD} + b\sigma^2_{RA/CD} + ab\sigma^2_{R/CD} + r\theta^2_{ABCD} + ra\theta^2_{BCD} + rb\theta^2_{ACD} + rc\theta^2_{ABD}$
ACD	$\sigma^2_{RAB/CD} + a\sigma^2_{RB/CD} + b\sigma^2_{RA/CD} + ab\sigma^2_{R/CD} + r\theta^2_{ABCD} + ra\theta^2_{BCD} + rb\theta^2_{ACD}$
BCD	$\sigma^2_{RAB/CD} + a\sigma^2_{RB/CD} + b\sigma^2_{RA/CD} + ab\sigma^2_{R/CD} + r\theta^2_{ABCD} + ra\theta^2_{BCD}$
ABCD	$\sigma^2_{RAB/CD} + a\sigma^2_{RB/CD} + b\sigma^2_{RA/CD} + ab\sigma^2_{R/CD} + r\theta^2_{ABCD}$
R/CD	$\sigma^2_{RAB/CD} + a\sigma^2_{RB/CD} + b\sigma^2_{RA/CD} + ab\sigma^2_{R/CD}$
RA/CD	$\sigma^2_{RAB/CD} + a\sigma^2_{RB/CD} + b\sigma^2_{RA/CD}$
RB/CD	$\sigma^2_{RAB/CD} + a\sigma^2_{RB/CD}$
RAB/CD	$\sigma^2_{RAB/CD}$

Langkah ketiga (langkah terakhir)

SV	EMS
A	$\sigma^2_{RAB/CD} + a\sigma^2_{RB/CD} + b\sigma^2_{RA/CD} + ab\sigma^2_{R/CD} + r\theta^2_{ABCD} + ra\theta^2_{BCD} + rb\theta^2_{ACD} + rc\theta^2_{ABD} + rd\theta^2_{ABC} + rab\theta^2_{CD} + rac\theta^2_{BD} + rad\theta^2_{BC} + rbc\theta^2_{AD} + rbd\theta^2_{AC} + rcd\theta^2_{AB} + rbc\theta^2_{D} + rabd\theta^2_C + racd\theta^2_B + rbcd\theta^2_A$
B	$\sigma^2_{RAB/CD} + a\sigma^2_{RB/CD} + b\sigma^2_{RA/CD} + ab\sigma^2_{R/CD} + r\theta^2_{ABCD} + ra\theta^2_{BCD} + rb\theta^2_{ACD} + rc\theta^2_{ABD} + rd\theta^2_{ABC} + rab\theta^2_{CD} + rac\theta^2_{BD} + rad\theta^2_{BC} + rbc\theta^2_{AD} + rbd\theta^2_{AC} + rcd\theta^2_{AB} + rbc\theta^2_{D} + rabd\theta^2_C + racd\theta^2_B$
C	$\sigma^2_{RAB/CD} + a\sigma^2_{RB/CD} + b\sigma^2_{RA/CD} + ab\sigma^2_{R/CD} + r\theta^2_{ABCD} + ra\theta^2_{BCD} + rb\theta^2_{ACD} + rc\theta^2_{ABD} + rd\theta^2_{ABC} + rab\theta^2_{CD} + rac\theta^2_{BD} + rad\theta^2_{BC} + rbc\theta^2_{AD} + rbd\theta^2_{AC} + rcd\theta^2_{AB} + rbc\theta^2_{D} + rabd\theta^2_C$

SV	EMS
D	$\sigma^2_{RAB/CD} + a\sigma^2_{RB/CD} + b\sigma^2_{RA/CD} + ab\sigma^2_{R/CD} + \Gamma\theta^2_{ABCD} + \Gamma a\theta^2_{BCD} + \Gamma b\theta^2_{ACD} + \Gamma c\theta^2_{ABD} + rd\theta^2_{ABC} + rab\theta^2_{CD} + rac\theta^2_{BD} + rad\theta^2_{BC} + rbc\theta^2_{AD} + rbd\theta^2_{AC} + rcd\theta^2_{AB} + abc\theta^2_D$
AB	$\sigma^2_{RAB/CD} + a\sigma^2_{RB/CD} + b\sigma^2_{RA/CD} + ab\sigma^2_{R/CD} + \Gamma\theta^2_{ABCD} + \Gamma a\theta^2_{BCD} + \Gamma b\theta^2_{ACD} + \Gamma c\theta^2_{ABD} + rd\theta^2_{ABC} + rab\theta^2_{CD} + rac\theta^2_{BD} + rad\theta^2_{BC} + rbc\theta^2_{AD} + rbd\theta^2_{AC} + rcd\theta^2_{AB}$
AC	$\sigma^2_{RAB/CD} + a\sigma^2_{RB/CD} + b\sigma^2_{RA/CD} + ab\sigma^2_{R/CD} + \Gamma\theta^2_{ABCD} + \Gamma a\theta^2_{BCD} + \Gamma b\theta^2_{ACD} + \Gamma c\theta^2_{ABD} + rd\theta^2_{ABC} + rab\theta^2_{CD} + rac\theta^2_{BD} + rad\theta^2_{BC} + rbc\theta^2_{AD} + rbd\theta^2_{AC}$
AD	$\sigma^2_{RAB/CD} + a\sigma^2_{RB/CD} + b\sigma^2_{RA/CD} + ab\sigma^2_{R/CD} + \Gamma\theta^2_{ABCD} + \Gamma a\theta^2_{BCD} + \Gamma b\theta^2_{ACD} + \Gamma c\theta^2_{ABD} + rd\theta^2_{ABC} + rab\theta^2_{CD} + rac\theta^2_{BD} + rad\theta^2_{BC} + rbc\theta^2_{AD}$
BC	$\sigma^2_{RAB/CD} + a\sigma^2_{RB/CD} + b\sigma^2_{RA/CD} + ab\sigma^2_{R/CD} + \Gamma\theta^2_{ABCD} + \Gamma a\theta^2_{BCD} + \Gamma b\theta^2_{ACD} + \Gamma c\theta^2_{ABD} + rd\theta^2_{ABC} + rab\theta^2_{CD} + rac\theta^2_{BD} + rad\theta^2_{BC}$
BD	$\sigma^2_{RAB/CD} + a\sigma^2_{RB/CD} + b\sigma^2_{RA/CD} + ab\sigma^2_{R/CD} + \Gamma\theta^2_{ABCD} + \Gamma a\theta^2_{BCD} + \Gamma b\theta^2_{ACD} + \Gamma c\theta^2_{ABD} + rd\theta^2_{ABC} + rab\theta^2_{CD} + rac\theta^2_{BD}$
CD	$\sigma^2_{RAB/CD} + a\sigma^2_{RB/CD} + b\sigma^2_{RA/CD} + ab\sigma^2_{R/CD} + \Gamma\theta^2_{ABCD} + \Gamma a\theta^2_{BCD} + \Gamma b\theta^2_{ACD} + \Gamma c\theta^2_{ABD} + rd\theta^2_{ABC} + rab\theta^2_{CD}$
ABC	$\sigma^2_{RAB/CD} + a\sigma^2_{RB/CD} + b\sigma^2_{RA/CD} + ab\sigma^2_{R/CD} + \Gamma\theta^2_{ABCD} + \Gamma a\theta^2_{BCD} + \Gamma b\theta^2_{ACD} + \Gamma c\theta^2_{ABD} + rd\theta^2_{ABC}$
ABD	$\sigma^2_{RAB/CD} + a\sigma^2_{RB/CD} + b\sigma^2_{RA/CD} + ab\sigma^2_{R/CD} + \Gamma\theta^2_{ABCD} + \Gamma a\theta^2_{BCD} + \Gamma b\theta^2_{ACD} + \Gamma c\theta^2_{ABD}$
ACD	$\sigma^2_{RAB/CD} + a\sigma^2_{RB/CD} + b\sigma^2_{RA/CD} + ab\sigma^2_{R/CD} + \Gamma\theta^2_{ABCD} + \Gamma a\theta^2_{BCD} + \Gamma b\theta^2_{ACD}$
BCD	$\sigma^2_{RAB/CD} + a\sigma^2_{RB/CD} + b\sigma^2_{RA/CD} + ab\sigma^2_{R/CD} + \Gamma\theta^2_{ABCD} + \Gamma a\theta^2_{BCD}$
ABCD	$\sigma^2_{RAB/CD} + a\sigma^2_{RB/CD} + b\sigma^2_{RA/CD} + ab\sigma^2_{R/CD} + \Gamma\theta^2_{ABCD}$
R/CD	$\sigma^2_{RAB/CD} + a\sigma^2_{RB/CD} + b\sigma^2_{RA/CD} + ab\sigma^2_{R/CD}$
RA/CD	$\sigma^2_{RAB/CD} + a\sigma^2_{RB/CD} + b\sigma^2_{RA/CD}$
RB/CD	$\sigma^2_{RAB/CD} + a\sigma^2_{RB/CD}$
RAB/CD	$\sigma^2_{RAB/CD}$

**Tabel 29 Anava Model 2 (Faktor ABCD Tetap)**

SV	Df	Fhitung	Ftabel
A	a-1=1	$F_{hitung}(A) = \frac{KT(A)}{KT(RA/CD)}$	$F_{\alpha;db(A);db(RA/CD)}$
B	b-1=1	$F_{hitung}(B) = \frac{KT(B)}{KT(RB/CD)}$	$F_{\alpha;db(B);db(RB/CD)}$
C	c-1=1	$F_{hitung}(C) = \frac{KT(C)}{KT(R/CD)}$	$F_{\alpha;db(C);db(R/CD)}$
D	d-1=1	$F_{hitung}(D) = \frac{KT(D)}{KT(R/CD)}$	$F_{\alpha;db(D);db(R/CD)}$

SV	Df	Fhitung	Ftabel
AB	$(a-1)(b-1)=1$	$F_{hitung}(AB) = \frac{KT(AB)}{KT(RAB/CD)}$	$F_{\alpha;db(AB);db(RAB/CD)}$
AC	$(a-1)(c-1)=1$	$F_{hitung}(AC) = \frac{KT(AC)}{KT(RA/CD)}$	$F_{\alpha;db(AC);db(RA/CD)}$
AD	$(a-1)(d-1)=1$	$F_{hitung}(AD) = \frac{KT(AD)}{KT(RA/CD)}$	$F_{\alpha;db(AD);db(RA/CD)}$
BC	$(b-1)(c-1)=1$	$F_{hitung}(BC) = \frac{KT(BC)}{KT(RB/CD)}$	$F_{\alpha;db(BC);db(RB/CD)}$
BD	$(b-1)(d-1)=1$	$F_{hitung}(BD) = \frac{KT(BD)}{KT(RB/CD)}$	$F_{\alpha;db(BD);db(RB/CD)}$
CD	$(c-1)(d-1)=1$	$F_{hitung}(CD) = \frac{KT(CD)}{KT(R/CD)}$	$F_{\alpha;db(CD);db(R/CD)}$
ABC	$(a-1)(b-1)(c-1)=1$	$F_{hitung}(ABC) = \frac{KT(ABC)}{KT(RAB/CD)}$	$F_{\alpha;db(ABC);db(RAB/CD)}$
ABD	$(a-1)(b-1)(d-1)=1$	$F_{hitung}(ABD) = \frac{KT(ABD)}{KT(RAB/CD)}$	$F_{\alpha;db(ABD);db(RAB/CD)}$
ACD	$(a-1)(c-1)(d-1)=1$	$F_{hitung}(ACD) = \frac{KT(ACD)}{KT(RA/CD)}$	$F_{\alpha;db(ACD);db(RA/CD)}$
BCD	$(b-1)(c-1)(d-1)=1$	$F_{hitung}(BCD) = \frac{KT(BCD)}{KT(RB/CD)}$	$F_{\alpha;db(BCD);db(RB/CD)}$
ABCD	$(a-1)(b-1)(c-1)(d-1)=1$	$F_{hitung}(ABCD) = \frac{KT(ABCD)}{KT(RAB/CD)}$	$F_{\alpha;db(ABCD);db(RAB/CD)}$

### Model 3. Faktor A B C acak & D tetap

**Tabel 30 Anava Model 3 (Faktor A B C acak & D tetap)**

SV	Df	Fhitung	Ftabel
AB	$(a-1)(b-1)=1$	$F_{hitung}(AB) = \frac{KT(AB)}{KT(ABC)}$	$F_{\alpha;db(AB);db(ABC)}$
ABC	$(a-1)(b-1)(c-1)=1$	$F_{hitung}(ABC) = \frac{KT(ABC)}{KT(RAB/CD)}$	$F_{\alpha;db(ABC);db(RAB/CD)}$
ABD	$(a-1)(b-1)(d-1)=1$	$F_{hitung}(ABD) = \frac{KT(ABD)}{KT(ABCD)}$	$F_{\alpha;db(ABD);db(ABCD)}$
ACD	$(a-1)(c-1)(d-1)=1$		
BCD	$(b-1)(c-1)(d-1)=1$	$F_{hitung}(BCD) = \frac{KT(BCD)}{KT(RB/CD)}$	$F_{\alpha;db(BCD);db(RB/CD)}$
ABCD	$(a-1)(b-1)(c-1)(d-1)=1$	$F_{hitung}(ABCD) = \frac{KT(ABCD)}{KT(RAB/CD)}$	$F_{\alpha;db(ABCD);db(RAB/CD)}$

### Model 4. Faktor A B D acak & C tetap

**Tabel 31 Anava Model 4 (Faktor A B D acak & C tetap)**

SV	Df	Fhitung	Ftabel
AB	$(a-1)(b-1)=1$	$F_{hitung}(AB) = \frac{KT(AB)}{KT(ABD)}$	$F_{\alpha;db(AB);db(ABD)}$
ABC	$(a-1)(b-1)(c-1)=1$	$F_{hitung}(ABC) = \frac{KT(ABC)}{KT(ABCD)}$	$F_{\alpha;db(ABC);db(ABCD)}$
ABD	$(a-1)(b-1)(d-1)=1$	$F_{hitung}(ABD) = \frac{KT(ABD)}{KT(RAB/CD)}$	$F_{\alpha;db(ABD);db(RAB/CD)}$
ABCD	$(a-1)(b-1)(c-1)(d-1)=1$	$F_{hitung}(ABCD) = \frac{KT(ABCD)}{KT(RAB/CD)}$	$F_{\alpha;db(ABCD);db(RAB/CD)}$

**Model 5. Faktor A C D acak & B tetap**

**Tabel 32 Anava Model 5 (Faktor A C D acak & B tetap)**

SV	Df	Fhitung	Ftabel
AC	$(a-1)(c-1)=1$	$F_{hitung}(AC) = \frac{KT(AC)}{KT(ACD)}$	$F_{\alpha;db(AC);db(ACD)}$
AD	$(a-1)(d-1)=1$	$F_{hitung}(AD) = \frac{KT(AD)}{KT(ACD)}$	$F_{\alpha;db(AD);db(ACD)}$
ABC	$(a-1)(b-1)(c-1)=1$	$F_{hitung}(ABC) = \frac{KT(ABC)}{KT(ABCD)}$	$F_{\alpha;db(ABC);db(ABCD)}$
ABD	$(a-1)(b-1)(d-1)=1$	$F_{hitung}(ABD) = \frac{KT(ABD)}{KT(ABCD)}$	$F_{\alpha;db(ABD);db(ABCD)}$
ACD	$(a-1)(c-1)(d-1)=1$	$F_{hitung}(ACD) = \frac{KT(ACD)}{KT(RA/CD)}$	$F_{\alpha;db(ACD);db(RA/CD)}$
ABCD	$(a-1)(b-1)(c-1)(d-1)=1$	$F_{hitung}(ABCD) = \frac{KT(ABCD)}{KT(RAB/CD)}$	$F_{\alpha;db(ABCD);db(RAB/CD)}$

**Model 6. Faktor B C D acak & A tetap**

**Tabel 33 Anava Model 6 (Faktor B C D acak & A tetap)**

SV	Df	Fhitung	Ftabel
BC	$(b-1)(c-1)=1$	$F_{hitung}(BC) = \frac{KT(BC)}{KT(BCD)}$	$F_{\alpha;db(BC);db(BCD)}$
BD	$(b-1)(d-1)=1$	$F_{hitung}(BD) = \frac{KT(BD)}{KT(BCD)}$	$F_{\alpha;db(BD);db(BCD)}$
ABC	$(a-1)(b-1)(c-1)=1$	$F_{hitung}(ABC) = \frac{KT(ABC)}{KT(ABCD)}$	$F_{\alpha;db(ABC);db(ABCD)}$
ABD	$(a-1)(b-1)(d-1)=1$	$F_{hitung}(ABD) = \frac{KT(ABD)}{KT(ABCD)}$	$F_{\alpha;db(ABD);db(ABCD)}$

BCD	$(b-1)(c-1)(d-1)=1$	$F_{hitung}(BCD) = \frac{KT(BCD)}{KT(RB/CD)}$	$F_{\alpha;db(BCD);db(RB/CD)}$
ABCD	$(a-1)(b-1)(c-1)(d-1)=1$	$F_{hitung}(ABCD) = \frac{KT(ABCD)}{KT(RAB/CD)}$	$F_{\alpha;db(ABCD);db(RAB/CD)}$

### Model 7. Faktor A B Acak & C D Tetap

**Tabel 34 Anava Model 7 (Faktor A B Acak & C D Tetap)**

SV	Df	Fhitung	Ftabel
AB	$(a-1)(b-1)=1$	$F_{hitung}(AB) = \frac{KT(AB)}{KT(RAB/CD)}$	$F_{\alpha;db(AB);db(RAB/CD)}$
ABC	$(a-1)(b-1)(c-1)=1$	$F_{hitung}(ABC) = \frac{KT(ABC)}{KT(RAB/CD)}$	$F_{\alpha;db(ABC);db(RAB/CD)}$
ABD	$(a-1)(b-1)(d-1)=1$	$F_{hitung}(ABD) = \frac{KT(ABD)}{KT(RAB/CD)}$	$F_{\alpha;db(ABD);db(RAB/CD)}$
ABCD	$(a-1)(b-1)(c-1)(d-1)=1$	$F_{hitung}(ABCD) = \frac{KT(ABCD)}{KT(RAB/CD)}$	$F_{\alpha;db(ABCD);db(RAB/CD)}$

### Model 8. Faktor A C acak & B D tetap

**Tabel 35 Anava Model 8 (Faktor A C acak & B D tetap)**

SV	Df	Fhitung	Ftabel
A	$a-1=1$	$F_{hitung}(A) = \frac{KT(A)}{KT(AC)}$	$F_{\alpha;db(A);db(AC)}$
AB	$(a-1)(b-1)=1$	$F_{hitung}(AB) = \frac{KT(AB)}{KT(ABC)}$	$F_{\alpha;db(AB);db(ABC)}$
AC	$(a-1)(c-1)=1$	$F_{hitung}(AC) = \frac{KT(AC)}{KT(RA/CD)}$	$F_{\alpha;db(AC);db(RA/CD)}$
AD	$(a-1)(d-1)=1$	$F_{hitung}(AD) = \frac{KT(AD)}{KT(ACD)}$	$F_{\alpha;db(AD);db(ACD)}$
ABC	$(a-1)(b-1)(c-1)=1$	$F_{hitung}(ABC) = \frac{KT(ABC)}{KT(RAB/CD)}$	$F_{\alpha;db(ABC);db(RAB/CD)}$
ABD	$(a-1)(b-1)(d-1)=1$	$F_{hitung}(ABD) = \frac{KT(ABD)}{KT(ABCD)}$	$F_{\alpha;db(ABD);db(ABCD)}$
ACD	$(a-1)(c-1)(d-1)=1$	$F_{hitung}(ACD) = \frac{KT(ACD)}{KT(RA/CD)}$	$F_{\alpha;db(ACD);db(RA/CD)}$
ABCD	$(a-1)(b-1)(c-1)(d-1)=1$	$F_{hitung}(ABCD) = \frac{KT(ABCD)}{KT(RAB/CD)}$	$F_{\alpha;db(ABCD);db(RAB/CD)}$

### Model 9. Faktor B C acak & A D tetap

**Tabel 36 Anava Model 9 (Faktor A C acak & B D tetap)**

SV	Df	Fhitung	Ftabel
B	b-1=1	$F_{hitung}(B) = \frac{KT(B)}{KT(BC)}$	$F_{\alpha;db(B);db(BC)}$
AB	(a-1)(b-1)=1	$F_{hitung}(AB) = \frac{KT(AB)}{KT(ABC)}$	$F_{\alpha;db(AB);db(ABC)}$
BC	(b-1)(c-1)=1	$F_{hitung}(BC) = \frac{KT(BC)}{KT(RB/CD)}$	$F_{\alpha;db(BC);db(RB/CD)}$
BD	(b-1)(d-1)=1	$F_{hitung}(BD) = \frac{KT(BD)}{KT(BCD)}$	$F_{\alpha;db(BD);db(BCD)}$
ABC	(a-1)(b-1)(c-1)=1	$F_{hitung}(ABC) = \frac{KT(ABC)}{KT(RAB/CD)}$	$F_{\alpha;db(ABC);db(RAB/CD)}$
ABD	(a-1)(b-1)(d-1)=1	$F_{hitung}(ABD) = \frac{KT(ABD)}{KT(ABCD)}$	$F_{\alpha;db(ABD);db(ABCD)}$
BCD	(b-1)(c-1)(d-1)=1	$F_{hitung}(BCD) = \frac{KT(BCD)}{KT(RB/CD)}$	$F_{\alpha;db(BCD);db(RB/CD)}$
ABCD	(a-1)(b-1)(c-1)(d-1)=1	$F_{hitung}(ABCD) = \frac{KT(ABCD)}{KT(RAB/CD)}$	$F_{\alpha;db(ABCD);db(RAB/CD)}$

**Model 10. Faktor A D acak & B C tetap**

**Tabel 37 Anava Model 10 (A D acak & B C tetap)**

SV	Df	Fhitung	Ftabel
A	a-1=1	$F_{hitung}(A) = \frac{KT(A)}{KT(AD)}$	$F_{\alpha;db(A);db(AD)}$
AB	(a-1)(b-1)=1	$F_{hitung}(AB) = \frac{KT(AB)}{KT(ABD)}$	$F_{\alpha;db(AB);db(ABD)}$
AC	(a-1)(c-1)=1	$F_{hitung}(AC) = \frac{KT(AC)}{KT(ACD)}$	$F_{\alpha;db(AC);db(ACD)}$
AD	(a-1)(d-1)=1	$F_{hitung}(AD) = \frac{KT(AD)}{KT(RA/CD)}$	$F_{\alpha;db(AD);db(RA/CD)}$
ABC	(a-1)(b-1)(c-1)=1	$F_{hitung}(ABC) = \frac{KT(ABC)}{KT(ABCD)}$	$F_{\alpha;db(ABC);db(ABCD)}$
ABD	(a-1)(b-1)(d-1)=1	$F_{hitung}(ABD) = \frac{KT(ABD)}{KT(RAB/CD)}$	$F_{\alpha;db(ABD);db(RAB/CD)}$
ACD	(a-1)(c-1)(d-1)=1	$F_{hitung}(ACD) = \frac{KT(ACD)}{KT(RA/CD)}$	$F_{\alpha;db(ACD);db(RA/CD)}$
ABCD	(a-1)(b-1)(c-1)(d-1)=1	$F_{hitung}(ABCD) = \frac{KT(ABCD)}{KT(RAB/CD)}$	$F_{\alpha;db(ABCD);db(RAB/CD)}$

**Model 11. Faktor B D acak & A C tetap**

**Tabel 38 Anava Model 11 (B D acak & A C tetap)**

SV	Df	Fhitung	Ftabel
B	b-1=1	$F_{hitung}(B) = \frac{KT(B)}{KT(BD)}$	$F_{\alpha;db(B);db(BD)}$
AB	(a-1)(b-1)=1	$F_{hitung}(AB) = \frac{KT(AB)}{KT(ABD)}$	$F_{\alpha;db(AB);db(ABD)}$
BC	(b-1)(c-1)=1	$F_{hitung}(BC) = \frac{KT(BC)}{KT(BCD)}$	$F_{\alpha;db(BC);db(BCD)}$
BD	(b-1)(d-1)=1	$F_{hitung}(BD) = \frac{KT(BD)}{KT(RB/CD)}$	$F_{\alpha;db(BD);db(RB/CD)}$
ABC	(a-1)(b-1)(c-1)=1	$F_{hitung}(ABC) = \frac{KT(ABC)}{KT(ABCD)}$	$F_{\alpha;db(ABC);db(ABCD)}$
ABD	(a-1)(b-1)(d-1)=1	$F_{hitung}(ABD) = \frac{KT(ABD)}{KT(RAB/CD)}$	$F_{\alpha;db(ABD);db(RAB/CD)}$
BCD	(b-1)(c-1)(d-1)=1	$F_{hitung}(BCD) = \frac{KT(BCD)}{KT(RB/CD)}$	$F_{\alpha;db(BCD);db(RB/CD)}$
ABCD	(a-1)(b-1)(c-1)(d-1)=1	$F_{hitung}(ABCD) = \frac{KT(ABCD)}{KT(RAB/CD)}$	$F_{\alpha;db(ABCD);db(RAB/CD)}$

### Model 12. Faktor C D acak& A B tetap

Tabel 39 Anava Model 12 (Faktor C D acak& A B tetap)

SV	Df	Fhitung	Ftabel
C	c-1=1	$F_{hitung}(C) = \frac{KT(C)}{KT(CD)}$	$F_{\alpha;db(C);db(CD)}$
D	d-1=1	$F_{hitung}(D) = \frac{KT(D)}{KT(CD)}$	$F_{\alpha;db(D);db(CD)}$
AC	(a-1)(c-1)=1	$F_{hitung}(AC) = \frac{KT(AC)}{KT(ACD)}$	$F_{\alpha;db(AC);db(ACD)}$
AD	(a-1)(d-1)=1	$F_{hitung}(AD) = \frac{KT(AD)}{KT(ACD)}$	$F_{\alpha;db(AD);db(ACD)}$
BD	(b-1)(d-1)=1	$F_{hitung}(BD) = \frac{KT(BD)}{KT(BCD)}$	$F_{\alpha;db(BD);db(BCD)}$
CD	(c-1)(d-1)=1	$F_{hitung}(CD) = \frac{KT(CD)}{KT(R/CD)}$	$F_{\alpha;db(CD);db(R/CD)}$
ABC	(a-1)(b-1)(c-1)=1	$F_{hitung}(ABC) = \frac{KT(ABC)}{KT(ABCD)}$	$F_{\alpha;db(ABC);db(ABCD)}$
ABD	(a-1)(b-1)(d-1)=1	$F_{hitung}(ABD) = \frac{KT(ABD)}{KT(ABCD)}$	$F_{\alpha;db(ABD);db(ABCD)}$
ACD	(a-1)(c-1)(d-1)=1	$F_{hitung}(ACD) = \frac{KT(ACD)}{KT(RA/CD)}$	$F_{\alpha;db(ACD);db(RA/CD)}$
BCD	(b-1)(c-1)(d-1)=1	$F_{hitung}(BCD) = \frac{KT(BCD)}{KT(RB/CD)}$	$F_{\alpha;db(BCD);db(RB/CD)}$
ABCD	(a-1)(b-1)(c-1)(d-1)=1	$F_{hitung}(ABCD) = \frac{KT(ABCD)}{KT(RAB/CD)}$	$F_{\alpha;db(ABCD);db(RAB/CD)}$

**Model 13. Faktor A acak& B C D tetap**

**Tabel 40 Anava Model 13 (Faktor A acak& B C D tetap)**

SV	Df	Fhitung	Ftabel
A	a-1=1	$F_{hitung}(A) = \frac{KT(A)}{KT(RA/CD)}$	$F_{\alpha;db(A);db(RA/CD)}$
AB	(a-1)(b-1)=1	$F_{hitung}(AB) = \frac{KT(AB)}{KT(RAB/CD)}$	$F_{\alpha;db(AB);db(RAB/CD)}$
AC	(a-1)(c-1)=1	$F_{hitung}(AC) = \frac{KT(AC)}{KT(RA/CD)}$	$F_{\alpha;db(AC);db(RA/CD)}$
AD	(a-1)(d-1)=1	$F_{hitung}(AD) = \frac{KT(AD)}{KT(RA/CD)}$	$F_{\alpha;db(AD);db(RA/CD)}$
ABC	(a-1)(b-1)(c-1)=1	$F_{hitung}(ABC) = \frac{KT(ABC)}{KT(RAB/CD)}$	$F_{\alpha;db(ABC);db(RAB/CD)}$
ABD	(a-1)(b-1)(d-1)=1	$F_{hitung}(ABD) = \frac{KT(ABD)}{KT(RAB/CD)}$	$F_{\alpha;db(ABD);db(RAB/CD)}$
ACD	(a-1)(c-1)(d-1)=1	$F_{hitung}(ACD) = \frac{KT(ACD)}{KT(RA/CD)}$	$F_{\alpha;db(ACD);db(RA/CD)}$
ABCD	(a-1)(b-1)(c-1)(d-1)=1	$F_{hitung}(ABCD) = \frac{KT(ABCD)}{KT(RAB/CD)}$	$F_{\alpha;db(ABCD);db(RAB/CD)}$

**Model 14. Faktor B acak& A C D tetap**

**Tabel 41 Anava Model 14 (Faktor B acak& A C D tetap)**

SV	Df	Fhitung	Ftabel
B	b-1=1	$F_{hitung}(B) = \frac{KT(B)}{KT(RB/CD)}$	$F_{\alpha;db(B);db(RB/CD)}$
AB	(a-1)(b-1)=1	$F_{hitung}(AB) = \frac{KT(AB)}{KT(RAB/CD)}$	$F_{\alpha;db(AB);db(RAB/CD)}$
BC	(b-1)(c-1)=1	$F_{hitung}(BC) = \frac{KT(BC)}{KT(RB/CD)}$	$F_{\alpha;db(BC);db(RB/CD)}$
BD	(b-1)(d-1)=1	$F_{hitung}(BD) = \frac{KT(BD)}{KT(RB/CD)}$	$F_{\alpha;db(BD);db(RB/CD)}$
ABC	(a-1)(b-1)(c-1)=1	$F_{hitung}(ABC) = \frac{KT(ABC)}{KT(RAB/CD)}$	$F_{\alpha;db(ABC);db(RAB/CD)}$
ABD	(a-1)(b-1)(d-1)=1	$F_{hitung}(ABD) = \frac{KT(ABD)}{KT(RAB/CD)}$	$F_{\alpha;db(ABD);db(RAB/CD)}$
BCD	(b-1)(c-1)(d-1)=1	$F_{hitung}(BCD) = \frac{KT(BCD)}{KT(RB/CD)}$	$F_{\alpha;db(BCD);db(RB/CD)}$



SV	Df	Fhitung	Ftabel
ABCD	$(a-1)(b-1)(c-1)(d-1)=1$	$F_{hitung}(ABCD) = \frac{KT(ABCD)}{KT(RAB/CD)}$	$F_{\alpha;db(ABCD);db(RAB/CD)}$

### Model 15. Faktor C acak & A B D tetap

**Tabel 42 Anava Model 15 (Faktor C acak & A B D tetap)**

SV	Df	Fhitung	Ftabel
A	$a-1=1$	$F_{hitung}(A) = \frac{KT(A)}{KT(AC)}$	$F_{\alpha;db(A);db(AC)}$
B	$b-1=1$	$F_{hitung}(B) = \frac{KT(B)}{KT(BC)}$	$F_{\alpha;db(B);db(BC)}$
C	$c-1=1$	$F_{hitung}(C) = \frac{KT(C)}{KT(R/CD)}$	$F_{\alpha;db(C);db(R/CD)}$
D	$d-1=1$	$F_{hitung}(D) = \frac{KT(D)}{KT(CD)}$	$F_{\alpha;db(D);db(CD)}$
AB	$(a-1)(b-1)=1$	$F_{hitung}(AB) = \frac{KT(AB)}{KT(ABC)}$	$F_{\alpha;db(AB);db(ABC)}$
AC	$(a-1)(c-1)=1$	$F_{hitung}(AC) = \frac{KT(AC)}{KT(RA/CD)}$	$F_{\alpha;db(AC);db(RA/CD)}$
AD	$(a-1)(d-1)=1$	$F_{hitung}(AD) = \frac{KT(AD)}{KT(ACD)}$	$F_{\alpha;db(AD);db(ACD)}$
BC	$(b-1)(c-1)=1$	$F_{hitung}(BC) = \frac{KT(BC)}{KT(RB/CD)}$	$F_{\alpha;db(BC);db(RB/CD)}$
BD	$(b-1)(d-1)=1$	$F_{hitung}(BD) = \frac{KT(BD)}{KT(BCD)}$	$F_{\alpha;db(BD);db(BCD)}$
CD	$(c-1)(d-1)=1$	$F_{hitung}(CD) = \frac{KT(CD)}{KT(R/CD)}$	$F_{\alpha;db(CD);db(R/CD)}$
ABC	$(a-1)(b-1)(c-1)=1$	$F_{hitung}(ABC) = \frac{KT(ABC)}{KT(RAB/CD)}$	$F_{\alpha;db(ABC);db(RAB/CD)}$
ABD	$(a-1)(b-1)(d-1)=1$	$F_{hitung}(ABD) = \frac{KT(ABD)}{KT(ABCD)}$	$F_{\alpha;db(ABD);db(ABCD)}$
ACD	$(a-1)(c-1)(d-1)=1$	$F_{hitung}(ACD) = \frac{KT(ACD)}{KT(RA/CD)}$	$F_{\alpha;db(ACD);db(RA/CD)}$
BCD	$(b-1)(c-1)(d-1)=1$	$F_{hitung}(BCD) = \frac{KT(BCD)}{KT(RB/CD)}$	$F_{\alpha;db(BCD);db(RB/CD)}$
ABCD	$(a-1)(b-1)(c-1)(d-1)=1$	$F_{hitung}(ABCD) = \frac{KT(ABCD)}{KT(RAB/CD)}$	$F_{\alpha;db(ABCD);db(RAB/CD)}$

### Model 16. Faktor D acak & A B C tetap

**Tabel 43 Anava Model 15 (Faktor D acak & A B C tetap)**

SV	Df	Fhitung	Ftabel
A	a-1=1	$F_{hitung}(A) = \frac{KT(A)}{KT(AD)}$	$F_{\alpha;db(A);db(AD)}$
B	b-1=1	$F_{hitung}(B) = \frac{KT(B)}{KT(BD)}$	$F_{\alpha;db(B);db(BD)}$
C	c-1=1	$F_{hitung}(C) = \frac{KT(C)}{KT(CD)}$	$F_{\alpha;db(C);db(CD)}$
D	d-1=1	$F_{hitung}(D) = \frac{KT(D)}{KT(R/CD)}$	$F_{\alpha;db(D);db(R/CD)}$
AB	(a-1)(b-1)=1	$F_{hitung}(AB) = \frac{KT(AB)}{KT(ABD)}$	$F_{\alpha;db(AB);db(ABD)}$
AC	(a-1)(c-1)=1	$F_{hitung}(AC) = \frac{KT(AC)}{KT(ACD)}$	$F_{\alpha;db(AC);db(ACD)}$
AD	(a-1)(d-1)=1	$F_{hitung}(AD) = \frac{KT(AD)}{KT(RA/CD)}$	$F_{\alpha;db(AD);db(RA/CD)}$
BC	(b-1)(c-1)=1	$F_{hitung}(BC) = \frac{KT(BC)}{KT(BCD)}$	$F_{\alpha;db(BC);db(BCD)}$
BD	(b-1)(d-1)=1	$F_{hitung}(BD) = \frac{KT(BD)}{KT(RB/CD)}$	$F_{\alpha;db(BD);db(RB/CD)}$
CD	(c-1)(d-1)=1	$F_{hitung}(CD) = \frac{KT(CD)}{KT(R/CD)}$	$F_{\alpha;db(CD);db(R/CD)}$
ABC	(a-1)(b-1)(c-1)=1	$F_{hitung}(ABC) = \frac{KT(ABC)}{KT(ABCD)}$	$F_{\alpha;db(ABC);db(ABCD)}$
ABD	(a-1)(b-1)(d-1)=1	$F_{hitung}(ABD) = \frac{KT(ABD)}{KT(RAB/CD)}$	$F_{\alpha;db(ABD);db(RAB/CD)}$
ACD	(a-1)(c-1)(d-1)=1	$F_{hitung}(ACD) = \frac{KT(ACD)}{KT(RA/CD)}$	$F_{\alpha;db(ACD);db(RA/CD)}$
BCD	(b-1)(c-1)(d-1)=1	$F_{hitung}(BCD) = \frac{KT(BCD)}{KT(RB/CD)}$	$F_{\alpha;db(BCD);db(RB/CD)}$
ABCD	(a-1)(b-1)(c-1)(d-1)=1	$F_{hitung}(ABCD) = \frac{KT(ABCD)}{KT(RAB/CD)}$	$F_{\alpha;db(ABCD);db(RAB/CD)}$

**BAB V**

**DIAGRAM BLOK DENGAN TERDAPAT KETERSARANGAN PADA  
FAKTOR UTAMA DAN TIDAK TERDAPAT *REPEATED MEASUREMENT***

Tipe diagram blok ini juga memiliki banyak kemungkinan model karena pengaruh kondisi faktor utama yang tersarang, yaitu bisa 1 atau 2 atau 3 faktor utama yang tersarang. Sehingga, memungkinkan ditemukan banyak model diagram blok dengan sumber variansi yang berbeda. Model-model diagram blok pada bagian ini kemungkinannya lebih banyak dari sebelumnya karena kombinasi tersarang pada faktor utamanya yang menyebabkan kemungkinannya lebih banyak. Model-model diagram blok nya antara lain ditunjukkan pada tabel berikut ini:

**Tabel 44 Diagram Blok Model 1: B tersarang A Faktor Utama dan Tidak Terdapat *Repeated Measurement***

		A1		A2	
		B1	B2	B3	B4
C1	D1	R1-R3	R4-R6	R7-R9	R10-R12
	D2	R13-R15	R16-R18	R19-R21	R22-R24
C2	D1	R25-R27	R28-R30	R31-R33	R34-R36
	D2	R37-R39	R40-R42	R43-R45	R46-R48

Untuk mempermudah mencari Model-model diagram blok nya maka tabel ditransformasi menjadi seperti di bawah ini akan tetapi maknanya tetap sama.

**Tabel 45 Diagram Blok Model 1 B tersarang A**

A1								A2							
B1				B2				B3				B4			
C1		C2		C1		C2		C1		C2		C1		C2	
D1	D2	D1	D2	D1	D2	D1	D2	D1	D2	D1	D2	D1	D2	D1	D2
R1	R4	R7	R10	R13	R16	R19	R22	R25	R28	R31	R34	R37	R40	R43	R46
-	-	-	-	-	-	-	-	-	-	-	-	-	-	-	-
R3	R6	R9	R12	R15	R18	R21	R24	R27	R30	R33	R36	R39	R42	R45	R48

**Tabel 46 Diagram Blok Model 2 C tersarang B**

A1								A2							
B1				B2				B1				B2			
C1		C2		C3		C4		C1		C2		C3		C4	
D1	D2	D1	D2	D1	D2	D1	D2	D1	D2	D1	D2	D1	D2	D1	D2
R1	R4	R7	R10	R13	R16	R19	R22	R25	R28	R31	R34	R37	R40	R43	R46
-	-	-	-	-	-	-	-	-	-	-	-	-	-	-	-
R3	R6	R9	R12	R15	R18	R21	R24	R27	R30	R33	R36	R39	R42	R45	R48

**Tabel 47 Diagram Blok Model 3 C tersarang A dan C tersarang B**

A1								A2							
B1				B2				B1				B2			
C1		C2		C3		C4		C5		C6		C7		C8	
D1	D2	D1	D2	D1	D2	D1	D2	D1	D2	D1	D2	D1	D2	D1	D2
R1	R4	R7	R10	R13	R16	R19	R22	R25	R28	R31	R34	R37	R40	R43	R46
-	-	-	-	-	-	-	-	-	-	-	-	-	-	-	-
R3	R6	R9	R12	R15	R18	R21	R24	R27	R30	R33	R36	R39	R42	R45	R48

**Tabel 48 Diagram Blok Model 4 D tersarang C**

A1								A2							
B1				B2				B1				B2			
C1		C2		C1		C2		C1		C2		C1		C2	
D1	D2	D3	D4	D1	D2	D3	D4	D1	D2	D3	D4	D1	D2	D3	D4
R1	R4	R7	R10	R13	R16	R19	R22	R25	R28	R31	R34	R37	R40	R43	R46
-	-	-	-	-	-	-	-	-	-	-	-	-	-	-	-
R3	R6	R9	R12	R15	R18	R21	R24	R27	R30	R33	R36	R39	R42	R45	R48

**Tabel 49 Diagram Blok Model 5 D tersarang C dan D tersarang B**

A1								A2							
B1				B2				B1				B2			
C1		C2		C1		C2		C1		C2		C1		C2	
D1	D2	D3	D4	D5	D6	D7	D8	D1	D2	D3	D4	D5	D6	D7	D8
R1	R4	R7	R10	R13	R16	R19	R22	R25	R28	R31	R34	R37	R40	R43	R46
-	-	-	-	-	-	-	-	-	-	-	-	-	-	-	-
R3	R6	R9	R12	R15	R18	R21	R24	R27	R30	R33	R36	R39	R42	R45	R48

**Tabel 50 Diagram Blok Model 6 D tersarang A, D tersarang B, dan D tersarang C**

A1								A2							
B1				B2				B1				B2			
C1		C2		C1		C2		C1		C2		C1		C2	
D1	D2	D3	D4	D5	D6	D7	D8	D9	D10	D11	D12	D13	D14	D15	D16
R1	R4	R7	R10	R13	R16	R19	R22	R25	R28	R31	R34	R37	R40	R43	R46
-	-	-	-	-	-	-	-	-	-	-	-	-	-	-	-
R3	R6	R9	R12	R15	R18	R21	R24	R27	R30	R33	R36	R39	R42	R45	R48

**Tabel 51 Diagram Blok Model 7 B tersarang A dan C tersarang B**

A1								A2							
B1				B2				B3				B4			
C1		C2		C3		C4		C1		C2		C3		C4	
D1	D2	D1	D2	D1	D2	D1	D2	D1	D2	D1	D2	D1	D2	D1	D2
R1	R4	R7	R10	R13	R16	R19	R22	R25	R28	R31	R34	R37	R40	R43	R46
-	-	-	-	-	-	-	-	-	-	-	-	-	-	-	-
R3	R6	R9	R12	R15	R18	R21	R24	R27	R30	R33	R36	R39	R42	R45	R48

**Tabel 52 Diagram Blok Model 8 B tersarang A,C tersarang B, dan C tersarang A**

A1								A2							
B1				B2				B3				B4			
C1		C2		C3		C4		C5		C6		C7		C8	
D1	D2	D1	D2	D1	D2	D1	D2	D1	D2	D1	D2	D1	D2	D1	D2
R1	R4	R7	R10	R13	R16	R19	R22	R25	R28	R31	R34	R37	R40	R43	R46
-	-	-	-	-	-	-	-	-	-	-	-	-	-	-	-
R3	R6	R9	R12	R15	R18	R21	R24	R27	R30	R33	R36	R39	R42	R45	R48

**Tabel 53 Diagram Blok Model 9 B tersarang di A, D tersarang di B, dan D tersarang di A**

A1								A2							
B1				B2				B3				B4			
C1		C2		C1		C2		C1		C2		C1		C2	
D1	D2	D3	D4	D5	D6	D7	D8	D1	D2	D3	D4	D5	D6	D7	D8
R1	R4	R7	R10	R13	R16	R19	R22	R25	R28	R31	R34	R37	R40	R43	R46
-	-	-	-	-	-	-	-	-	-	-	-	-	-	-	-
R3	R6	R9	R12	R15	R18	R21	R24	R27	R30	R33	R36	R39	R42	R45	R48

**Tabel 54 Diagram Blok Model 10 B tersarang di A, D tersarang di C, D tersarang di B, dan D tersarang di A**

A1								A2							
B1				B2				B3				B4			
C1		C2		C1		C2		C1		C2		C1		C2	
D1	D2	D3	D4	D5	D6	D7	D8	D9	D10	D11	D12	D13	D14	D15	D16
R1	R4	R7	R10	R13	R16	R19	R22	R25	R28	R31	R34	R37	R40	R43	R46
-	-	-	-	-	-	-	-	-	-	-	-	-	-	-	-
R3	R6	R9	R12	R15	R18	R21	R24	R27	R30	R33	R36	R39	R42	R45	R48

**Tabel 55 Diagram Blok Model 11 C tersarang di B dan D tersarang di C**

A1								A2							
B1				B2				B1				B2			
C1		C2		C3		C4		C1		C2		C3		C4	
D1	D2	D3	D4	D1	D2	D3	D4	D1	D2	D3	D4	D1	D2	D3	D4
R1	R4	R7	R10	R13	R16	R19	R22	R25	R28	R31	R34	R37	R40	R43	R46
-	-	-	-	-	-	-	-	-	-	-	-	-	-	-	-
R3	R6	R9	R12	R15	R18	R21	R24	R27	R30	R33	R36	R39	R42	R45	R48

**Tabel 56 Diagram Blok Model 12 C tersarang di B, D tersarang di C, dan D tersarang di B**

A1								A2							
B1				B2				B1				B2			
C1		C2		C3		C4		C1		C2		C3		C4	
D1	D2	D3	D4	D5	D6	D7	D8	D1	D2	D3	D4	D5	D6	D7	D8
R1	R4	R7	R10	R13	R16	R19	R22	R25	R28	R31	R34	R37	R40	R43	R46
-	-	-	-	-	-	-	-	-	-	-	-	-	-	-	-
R3	R6	R9	R12	R15	R18	R21	R24	R27	R30	R33	R36	R39	R42	R45	R48

**Tabel 57 Diagram Blok Model 13 C tersarang di B, D tersarang di C, D tersarang di B, dan D tersarang di A**

A1								A2							
B1				B2				B1				B2			
C1		C2		C3		C4		C1		C2		C3		C4	
D1	D2	D3	D4	D5	D6	D7	D8	D9	D10	D11	D12	D13	D14	D15	D8
R1	R4	R7	R10	R13	R16	R19	R22	R25	R28	R31	R34	R37	R40	R43	R46
-	-	-	-	-	-	-	-	-	-	-	-	-	-	-	-
R3	R6	R9	R12	R15	R18	R21	R24	R27	R30	R33	R36	R39	R42	R45	R48

**Tabel 58 Diagram Blok Model 14 C tersarang di A, C tersarang di B, dan D tersarang di C**

A1								A2							
B1				B2				B3				B4			
C1		C2		C3		C4		C5		C6		C7		C8	
D1	D2	D3	D4	D1	D2	D3	D4	D1	D2	D3	D4	D1	D2	D3	D4
R1	R4	R7	R10	R13	R16	R19	R22	R25	R28	R31	R34	R37	R40	R43	R46
-	-	-	-	-	-	-	-	-	-	-	-	-	-	-	-
R3	R6	R9	R12	R15	R18	R21	R24	R27	R30	R33	R36	R39	R42	R45	R48

**Tabel 59 Diagram Blok Model 15 C tersarang di A, C tersarang di B, D tersarang di C, dan D tersarang di B**

A1								A2							
B1				B2				B3				B4			
C1		C2		C3		C4		C5		C6		C7		C8	
D1	D2	D3	D4	D5	D6	D7	D8	D1	D2	D3	D4	D5	D6	D7	D8
R1	R4	R7	R10	R13	R16	R19	R22	R25	R28	R31	R34	R37	R40	R43	R46
-	-	-	-	-	-	-	-	-	-	-	-	-	-	-	-
R3	R6	R9	R12	R15	R18	R21	R24	R27	R30	R33	R36	R39	R42	R45	R48

**Tabel 60 Diagram Blok Model 16 C tersarang di A, C tersarang di B, D tersarang di C, D tersarang di B, dan D tersarang di A**

A1								A2							
B1				B2				B3				B4			
C1		C2		C3		C4		C5		C6		C7		C8	
D1	D2	D3	D4	D5	D6	D7	D8	D9	D10	D11	D12	D13	D14	D15	D16
R1	R4	R7	R10	R13	R16	R19	R22	R25	R28	R31	R34	R37	R40	R43	R46
-	-	-	-	-	-	-	-	-	-	-	-	-	-	-	-
R3	R6	R9	R12	R15	R18	R21	R24	R27	R30	R33	R36	R39	R42	R45	R48

Beberapa model diagram blok di atas barulah sebagian model saja, dan masih banyak model diagram blok yang lainnya yang belum disampaikan oleh penulis pada bab ini. Silahkan pembaca menentukan sendiri kemungkinan lainnya dengan 3 faktor utama yang tersarang sekaligus, yaitu faktor B, C, dan D tersarang pada A.

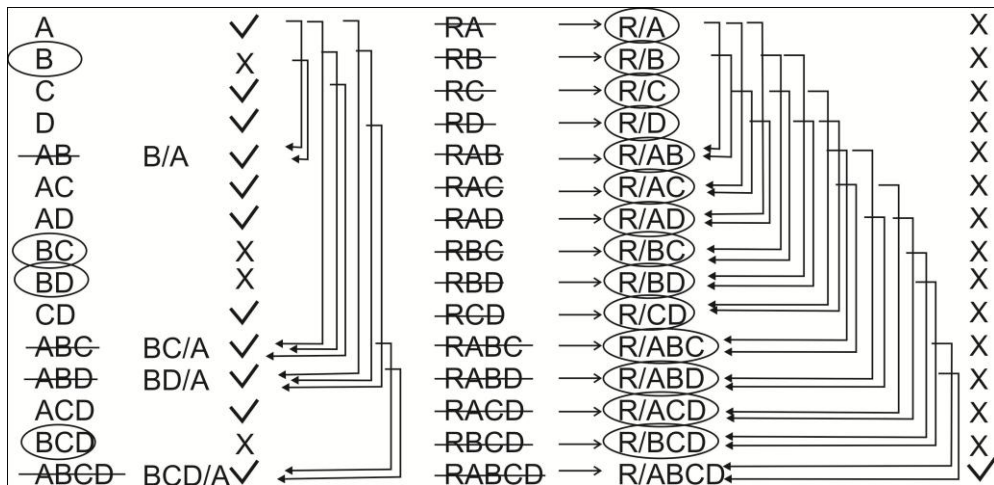

**Gambar 8 Menentukan Sumber Variansi Model 1: Terdapat Ketersarangan pada Faktor Utama dan Tidak Terdapat *Repeated Measurement***

Selanjutnya pembaca bisa menentukan SV untuk model yang lainnya. Dengan mengikuti alur atau langkah-langkah yang telah disajikan oleh penulis.

Kita ketahui bahwa estiap model diagram blok menghasilkan 16 model tabel ANAVA. Adapun kombinasinya adalah sebagai berikut:

**Tabel 61 Berbagai Kemungkinan Tabel Anava Terdapat Ketersarangan pada Faktor Utama dan Tidak Terdapat *Repeated Measurement***

Model	Faktor A	Faktor B	Faktor C	Faktor D
Model 1	A	A	A	A
Model 2	T	T	T	T
Model 3	A	A	A	T
Model 4	A	A	T	A
Model 5	A	T	A	A
Model 6	T	A	A	A
Model 7	A	A	T	T
Model 8	A	T	A	T
Model 9	T	A	A	T
Model 10	A	T	T	A
Model 11	T	A	T	A
Model 12	T	A	A	T
Model 13	A	T	T	T
Model 14	T	A	T	T
Model 15	T	T	A	T
Model 16	T	T	T	A

Keterangan :



A : Acak

T : Tetap

Dari 16 model diagram blok tersebut kemungkinan bisa ditemukan  $16 \times 16 = 256$  model tabel ANAVA. Akan tetapi, kali ini hanya akan ditentukan berbagai model tabel ANAVA untuk model diagram blok yang pertama. Selebihnya bisa dicoba dicari sendiri oleh para pembaca. Selamat mencoba.

Menentukan tabel ANAVA untuk model tabel ANAVA yang pertama

**Model 1. Faktor A B C D semua acak**

Tahapan Menentukan SV

langkah pertama

SV	EMS
A	$\sigma^2_{R/ABCD} + r\sigma^2_{BCD/A} + rc\sigma^2_{BD/A} + rd\sigma^2_{BC/A} + rcd\sigma^2_{B/A} + rb\sigma^2_{ACD} + rab\sigma^2_{CD} + rbc\sigma^2_{AD} + rbd\sigma^2_{AC} + rabc\sigma^2_D + rabd\sigma^2_C + rbcd\sigma^2_A$
C	$\sigma^2_{R/ABCD} + r\sigma^2_{BCD/A} + rc\sigma^2_{BD/A} + rd\sigma^2_{BC/A} + rcd\sigma^2_{B/A} + rb\sigma^2_{ACD} + rab\sigma^2_{CD} + rbc\sigma^2_{AD} + rbd\sigma^2_{AC} + rabc\sigma^2_D + rabd\sigma^2_C$
D	$\sigma^2_{R/ABCD} + r\sigma^2_{BCD/A} + rc\sigma^2_{BD/A} + rd\sigma^2_{BC/A} + rcd\sigma^2_{B/A} + rb\sigma^2_{ACD} + rab\sigma^2_{CD} + rbc\sigma^2_{AD} + rbd\sigma^2_{AC} + rabc\sigma^2_D$
AC	$\sigma^2_{R/ABCD} + r\sigma^2_{BCD/A} + rc\sigma^2_{BD/A} + rd\sigma^2_{BC/A} + rcd\sigma^2_{B/A} + rb\sigma^2_{ACD} + rab\sigma^2_{CD} + rbc\sigma^2_{AD} + rbd\sigma^2_{AC}$
AD	$\sigma^2_{R/ABCD} + r\sigma^2_{BCD/A} + rc\sigma^2_{BD/A} + rd\sigma^2_{BC/A} + rcd\sigma^2_{B/A} + rb\sigma^2_{ACD} + rab\sigma^2_{CD} + rbc\sigma^2_{AD}$
CD	$\sigma^2_{R/ABCD} + r\sigma^2_{BCD/A} + rc\sigma^2_{BD/A} + rd\sigma^2_{BC/A} + rcd\sigma^2_{B/A} + rb\sigma^2_{ACD} + rab\sigma^2_{CD}$
ACD	$\sigma^2_{R/ABCD} + r\sigma^2_{BCD/A} + rc\sigma^2_{BD/A} + rd\sigma^2_{BC/A} + rcd\sigma^2_{B/A} + rb\sigma^2_{ACD}$
B/A	$\sigma^2_{R/ABCD} + r\sigma^2_{BCD/A} + rc\sigma^2_{BD/A} + rd\sigma^2_{BC/A} + rcd\sigma^2_{B/A}$
BC/A	$\sigma^2_{R/ABCD} + r\sigma^2_{BCD/A} + rc\sigma^2_{BD/A} + rd\sigma^2_{BC/A}$
BD/A	$\sigma^2_{R/ABCD} + r\sigma^2_{BCD/A} + rc\sigma^2_{BD/A}$
BCD/A	$\sigma^2_{R/ABCD} + r\sigma^2_{BCD/A}$
R/ABCD	$\sigma^2_{R/ABCD}$

Langkah kedua (langkah terakhir)

SV	EMS
A	$\sigma^2_{R/ABCD} + r\sigma^2_{BCD/A} + rc\sigma^2_{BD/A} + rd\sigma^2_{BC/A} + rcd\sigma^2_{B/A} + rb\sigma^2_{ACD} + rab\sigma^2_{CD} + rbc\sigma^2_{AD} + rbd\sigma^2_{AC} + rabc\sigma^2_D + rabd\sigma^2_C + rbcd\sigma^2_A$

SV	EMS
C	$\sigma^2_{R/ABCD} + \sigma^2_{BCD/A} + \sigma^2_{BD/A} + \sigma^2_{BC/A} + \sigma^2_{B/A} + \sigma^2_{ACD} + \sigma^2_{CD} + \sigma^2_{AD} + \sigma^2_{AC} + \sigma^2_{D} + \sigma^2_{C}$
D	$\sigma^2_{R/ABCD} + \sigma^2_{BCD/A} + \sigma^2_{BD/A} + \sigma^2_{BC/A} + \sigma^2_{B/A} + \sigma^2_{ACD} + \sigma^2_{CD} + \sigma^2_{AD} + \sigma^2_{AC} + \sigma^2_{D}$
AC	$\sigma^2_{R/ABCD} + \sigma^2_{BCD/A} + \sigma^2_{BD/A} + \sigma^2_{BC/A} + \sigma^2_{B/A} + \sigma^2_{ACD} + \sigma^2_{CD} + \sigma^2_{AD} + \sigma^2_{AC}$
AD	$\sigma^2_{R/ABCD} + \sigma^2_{BCD/A} + \sigma^2_{BD/A} + \sigma^2_{BC/A} + \sigma^2_{B/A} + \sigma^2_{ACD} + \sigma^2_{CD} + \sigma^2_{AD}$
CD	$\sigma^2_{R/ABCD} + \sigma^2_{BCD/A} + \sigma^2_{BD/A} + \sigma^2_{BC/A} + \sigma^2_{B/A} + \sigma^2_{ACD} + \sigma^2_{CD}$
ACD	$\sigma^2_{R/ABCD} + \sigma^2_{BCD/A} + \sigma^2_{BD/A} + \sigma^2_{BC/A} + \sigma^2_{B/A} + \sigma^2_{ACD}$
B/A	$\sigma^2_{R/ABCD} + \sigma^2_{BCD/A} + \sigma^2_{BD/A} + \sigma^2_{BC/A} + \sigma^2_{B/A}$
BC/A	$\sigma^2_{R/ABCD} + \sigma^2_{BCD/A} + \sigma^2_{BD/A} + \sigma^2_{BC/A}$
BD/A	$\sigma^2_{R/ABCD} + \sigma^2_{BCD/A} + \sigma^2_{BD/A}$
BCD/A	$\sigma^2_{R/ABCD} + \sigma^2_{BCD/A}$
R/ABCD	$\sigma^2_{R/ABCD}$

**Tabel 62 Anava Model 1 (Faktor A B C D semua acak)**

SV	Df	Fhitung	Ftabel
CD	$(c-1)(d-1)=1$	$F_{hitung}(CD) = \frac{KT(CD)}{KT(ACD)}$	$F_{\alpha; db(CD); db(ACD)}$
ACD	$(a-1)(c-1)(d-1)=1$	$F_{hitung}(ACD) = \frac{KT(ACD)}{KT(BCD/A)}$	$F_{\alpha; db(ACD); db(BCD/A)}$

### Model 2. Faktor A B C D semua Tetap

langkah pertama

SV	EMS
A	$\sigma^2_{R/ABCD} + \sigma^2_{BCD/A} + \sigma^2_{BD/A} + \sigma^2_{BC/A} + \sigma^2_{B/A} + \sigma^2_{ACD} + \sigma^2_{CD} + \sigma^2_{AD} + \sigma^2_{AC} + \sigma^2_{D} + \sigma^2_{C} + \theta^2_{CD} + \theta^2_{AD} + \theta^2_{AC} + \theta^2_{D} + \theta^2_{C} + \theta^2_{A}$
C	$\sigma^2_{R/ABCD} + \sigma^2_{BCD/A} + \sigma^2_{BD/A} + \sigma^2_{BC/A} + \sigma^2_{B/A} + \sigma^2_{ACD} + \sigma^2_{CD} + \sigma^2_{AD} + \sigma^2_{AC} + \sigma^2_{D} + \sigma^2_{C} + \theta^2_{CD} + \theta^2_{AD} + \theta^2_{AC} + \theta^2_{D} + \theta^2_{C}$
D	$\sigma^2_{R/ABCD} + \sigma^2_{BCD/A} + \sigma^2_{BD/A} + \sigma^2_{BC/A} + \sigma^2_{B/A} + \sigma^2_{ACD} + \sigma^2_{CD} + \sigma^2_{AD} + \sigma^2_{AC} + \sigma^2_{D} + \sigma^2_{C} + \theta^2_{CD} + \theta^2_{AD} + \theta^2_{AC} + \theta^2_{D}$
AC	$\sigma^2_{R/ABCD} + \sigma^2_{BCD/A} + \sigma^2_{BD/A} + \sigma^2_{BC/A} + \sigma^2_{B/A} + \sigma^2_{ACD} + \sigma^2_{CD} + \sigma^2_{AD} + \sigma^2_{AC} + \theta^2_{CD} + \theta^2_{AD} + \theta^2_{AC}$
AD	$\sigma^2_{R/ABCD} + \sigma^2_{BCD/A} + \sigma^2_{BD/A} + \sigma^2_{BC/A} + \sigma^2_{B/A} + \sigma^2_{ACD} + \sigma^2_{CD} + \sigma^2_{AD} + \theta^2_{CD} + \theta^2_{AD}$



SV	EMS
AC	$\sigma^2_{R/ABCD} + r\sigma^2_{BCD/A} + rc\sigma^2_{BD/A} + rd\sigma^2_{BC/A} + rcd\sigma^2_{B/A} + rb\theta^2_{ACD} + rab\theta^2_{AC}$
AD	$\sigma^2_{R/ABCD} + r\sigma^2_{BCD/A} + rc\sigma^2_{BD/A} + rd\sigma^2_{BC/A} + rcd\sigma^2_{B/A} + rb\theta^2_{ACD} + rbd\theta^2_{AD}$
CD	$\sigma^2_{R/ABCD} + r\sigma^2_{BCD/A} + rc\sigma^2_{BD/A} + rd\sigma^2_{BC/A} + rcd\sigma^2_{B/A} + rb\theta^2_{ACD} + rab\theta^2_{AC}$
ACD	$\sigma^2_{R/ABCD} + r\sigma^2_{BCD/A} + rc\sigma^2_{BD/A} + rd\sigma^2_{BC/A} + rcd\sigma^2_{B/A} + rb\theta^2_{ACD}$
B/A	$\sigma^2_{R/ABCD} + r\sigma^2_{BCD/A} + rc\sigma^2_{BD/A} + rd\sigma^2_{BC/A} + rcd\sigma^2_{B/A}$
BC/A	$\sigma^2_{R/ABCD} + r\sigma^2_{BCD/A} + rc\sigma^2_{BD/A} + rd\sigma^2_{BC/A}$
BD/A	$\sigma^2_{R/ABCD} + r\sigma^2_{BCD/A} + rc\sigma^2_{BD/A}$
BCD/A	$\sigma^2_{R/ABCD} + r\sigma^2_{BCD/A}$
R/ABCD	$\sigma^2_{R/ABCD}$

**Tabel 63 Anava Model 2 (Faktor A B C D semua tetap)**

SV	Df	Fhitung	Ftabel
A	a-1=1	$F_{hitung}(A) = \frac{KT(A)}{KT(R/ABCD)}$	$F_{\alpha;db(A);db(R/ABCD)}$
C	c-1=1	$F_{hitung}(C) = \frac{KT(C)}{KT(R/ABCD)}$	$F_{\alpha;db(C);db(R/ABCD)}$
D	d-1=1	$F_{hitung}(D) = \frac{KT(D)}{KT(R/ABCD)}$	$F_{\alpha;db(D);db(R/ABCD)}$
AC	(a-1)(c-1)=1	$F_{hitung}(AC) = \frac{KT(AC)}{KT(R/ABCD)}$	$F_{\alpha;db(AC);db(R/ABCD)}$
AD	(a-1)(d-1)=1	$F_{hitung}(AD) = \frac{KT(AD)}{KT(R/ABCD)}$	$F_{\alpha;db(AD);db(R/ABCD)}$
CD	(c-1)(d-1)=1	$F_{hitung}(CD) = \frac{KT(CD)}{KT(R/ABCD)}$	$F_{\alpha;db(CD);db(R/ABCD)}$
ACD	(a-1)(c-1)(d-1)=1	$F_{hitung}(ACD) = \frac{KT(ACD)}{KT(R/ABCD)}$	$F_{\alpha;db(ACD);db(R/ABCD)}$

### Model 3. Faktor A B C acak & D tetap

**Tabel 64 Anava Model 3 (Faktor A B C acak & D tetap)**

SV	Df	Fhitung	Ftabel
C	c-1=1	$F_{hitung}(C) = \frac{KT(C)}{KT(AC)}$	$F_{\alpha;db(C);db(AC)}$
AC	(a-1)(c-1)=1	$F_{hitung}(AC) = \frac{KT(AC)}{KT(BC/A)}$	$F_{\alpha;db(AC);db(BC/A)}$

SV	Df	Fhitung	Ftabel
CD	$(c-1)(d-1)=1$	$F_{hitung}(CD) = \frac{KT(CD)}{KT(ACD)}$	$F_{\alpha;db(CD);db(ACD)}$
ACD	$(a-1)(c-1)(d-1)=1$	$F_{hitung}(ACD) = \frac{KT(ACD)}{KT(BCD/A)}$	$F_{\alpha;db(ACD);db(BCD/A)}$

#### Model 4. Faktor A B D acak & C tetap

**Tabel 65 Anava Model 4 (Faktor A B D acak & C tetap)**

SV	Df	Fhitung	Ftabel
D	$d-1=1$	$F_{hitung}(D) = \frac{KT(D)}{KT(AD)}$	$F_{\alpha;db(D);db(AD)}$
AD	$(a-1)(d-1)=1$	$F_{hitung}(AD) = \frac{KT(AD)}{KT(BD/A)}$	$F_{\alpha;db(AD);db(BD/A)}$
CD	$(c-1)(d-1)=1$	$F_{hitung}(CD) = \frac{KT(CD)}{KT(ACD)}$	$F_{\alpha;db(CD);db(ACD)}$
ACD	$(a-1)(c-1)(d-1)=1$	$F_{hitung}(ACD) = \frac{KT(ACD)}{KT(BCD/A)}$	$F_{\alpha;db(ACD);db(BCD/A)}$

#### Model 5. Faktor A C D acak & B tetap

**Tabel 66 Anava Model 5 (Faktor A C D acak & B tetap)**

SV	Df	Fhitung	Ftabel
AC	$(a-1)(c-1)=1$	$F_{hitung}(AC) = \frac{KT(AC)}{KT(ACD)}$	$F_{\alpha;db(AC);db(ACD)}$
AD	$(a-1)(d-1)=1$	$F_{hitung}(AD) = \frac{KT(AD)}{KT(ACD)}$	$F_{\alpha;db(AD);db(ACD)}$
CD	$(c-1)(d-1)=1$	$F_{hitung}(CD) = \frac{KT(CD)}{KT(ACD)}$	$F_{\alpha;db(CD);db(ACD)}$
ACD	$(a-1)(c-1)(d-1)=1$	$F_{hitung}(ACD) = \frac{KT(ACD)}{KT(R/ABCD)}$	$F_{\alpha;db(ACD);db(R/ABCD)}$

#### Model 6. Faktor B C D acak & A tetap

**Tabel 67 Anava Model 6 (Faktor B C D acak & A tetap)**

SV	Df	Fhitung	Ftabel
CD	$(c-1)(d-1)=1$	$F_{hitung}(CD) = \frac{KT(CD)}{KT(BCD/A)}$	$F_{\alpha;db(CD);db(BCD/A)}$
ACD	$(a-1)(c-1)(d-1)=1$	$F_{hitung}(ACD) = \frac{KT(ACD)}{KT(BCD/A)}$	$F_{\alpha;db(ACD);db(BCD/A)}$

#### Model 7. Faktor A B Acak & C D Tetap

**Tabel 68 Anava Model 7 (Faktor A B Acak & C D Tetap)**

SV	Df	Fhitung	Ftabel
A	a-1=1	$F_{hitung}(A) = \frac{KT(A)}{KT(B/A)}$	$F_{\alpha;db(A);db(B/A)}$
C	c-1=1	$F_{hitung}(C) = \frac{KT(C)}{KT(AC)}$	$F_{\alpha;db(C);db(AC)}$
D	d-1=1	$F_{hitung}(D) = \frac{KT(D)}{KT(AD)}$	$F_{\alpha;db(D);db(AD)}$
AC	(a-1)(c-1)=1	$F_{hitung}(AC) = \frac{KT(AC)}{KT(BC/A)}$	$F_{\alpha;db(AC);db(BC/A)}$
AD	(a-1)(d-1)=1	$F_{hitung}(AD) = \frac{KT(AD)}{KT(BD/A)}$	$F_{\alpha;db(AD);db(BD/A)}$
CD	(c-1)(d-1)=1	$F_{hitung}(CD) = \frac{KT(CD)}{KT(ACD)}$	$F_{\alpha;db(CD);db(ACD)}$
ACD	(a-1)(c-1)(d-1)=1	$F_{hitung}(ACD) = \frac{KT(ACD)}{KT(BCD/A)}$	$F_{\alpha;db(ACD);db(BCD/A)}$

**Model 8. Faktor A C acak & B D tetap**

**Tabel 69 Anava Model 8 (Faktor A C acak & B D tetap)**

SV	Df	Fhitung	Ftabel
A	a-1=1	$F_{hitung}(A) = \frac{KT(A)}{KT(AC)}$	$F_{\alpha;db(A);db(AC)}$
C	c-1=1	$F_{hitung}(C) = \frac{KT(C)}{KT(AC)}$	$F_{\alpha;db(C);db(AC)}$
AC	(a-1)(c-1)=1	$F_{hitung}(AC) = \frac{KT(AC)}{KT(R/ABCD)}$	$F_{\alpha;db(AC);db(R/ABCD)}$
AD	(a-1)(d-1)=1	$F_{hitung}(AD) = \frac{KT(AD)}{KT(ACD)}$	$F_{\alpha;db(AD);db(ACD)}$
CD	(c-1)(d-1)=1	$F_{hitung}(CD) = \frac{KT(CD)}{KT(ACD)}$	$F_{\alpha;db(CD);db(ACD)}$
ACD	(a-1)(c-1)(d-1)=1	$F_{hitung}(ACD) = \frac{KT(ACD)}{KT(R/ABCD)}$	$F_{\alpha;db(ACD);db(R/ABCD)}$

**Model 9. Faktor B C acak & A D tetap**

**Tabel 70 Anava Model 9 (Faktor B C acak & A D tetap)**

SV	Df	Fhitung	Ftabel
C	c-1=1	$F_{hitung}(C) = \frac{KT(C)}{KT(BC/A)}$	$F_{\alpha;db(C);db(BC/A)}$
AC	(a-1)(c-1)=1	$F_{hitung}(AC) = \frac{KT(AC)}{KT(BC/A)}$	$F_{\alpha;db(AC);db(BC/A)}$

SV	Df	Fhitung	Ftabel
CD	$(c-1)(d-1)=1$	$F_{hitung}(CD) = \frac{KT(CD)}{KT(BCD/A)}$	$F_{\alpha;db(CD);db(BCD/A)}$
ACD	$(a-1)(c-1)(d-1)=1$	$F_{hitung}(ACD) = \frac{KT(ACD)}{KT(BCD/A)}$	$F_{\alpha;db(ACD);db(BCD/A)}$

### Model 10. Faktor A D acak & B C tetap

**Tabel 71 Anava Model 10 (Faktor A D acak & B C tetap)**

SV	Df	Fhitung	Ftabel
A	$a-1=1$	$F_{hitung}(A) = \frac{KT(A)}{KT(AD)}$	$F_{\alpha;db(A);db(AD)}$
D	$d-1=1$	$F_{hitung}(D) = \frac{KT(D)}{KT(AD)}$	$F_{\alpha;db(D);db(AD)}$
AC	$(a-1)(c-1)=1$	$F_{hitung}(AC) = \frac{KT(AC)}{KT(ACD)}$	$F_{\alpha;db(AC);db(ACD)}$
AD	$(a-1)(d-1)=1$	$F_{hitung}(AD) = \frac{KT(AD)}{KT(R/ABCD)}$	$F_{\alpha;db(AD);db(R/ABCD)}$
CD	$(c-1)(d-1)=1$	$F_{hitung}(CD) = \frac{KT(CD)}{KT(ACD)}$	$F_{\alpha;db(CD);db(ACD)}$
ACD	$(a-1)(c-1)(d-1)=1$	$F_{hitung}(ACD) = \frac{KT(ACD)}{KT(R/ABCD)}$	$F_{\alpha;db(ACD);db(R/ABCD)}$

### Model 11. Faktor B D acak & A C tetap

**Tabel 72 Anava Model 11 (Faktor B D acak & A C tetap)**

SV	Df	Fhitung	Ftabel
D	$d-1=1$	$F_{hitung}(D) = \frac{KT(D)}{KT(BD/A)}$	$F_{\alpha;db(D);db(BD/A)}$
AD	$(a-1)(d-1)=1$	$F_{hitung}(AD) = \frac{KT(AD)}{KT(BD/A)}$	$F_{\alpha;db(AD);db(BD/A)}$
CD	$(c-1)(d-1)=1$	$F_{hitung}(CD) = \frac{KT(CD)}{KT(BCD/A)}$	$F_{\alpha;db(CD);db(BCD/A)}$
ACD	$(a-1)(c-1)(d-1)=1$	$F_{hitung}(ACD) = \frac{KT(ACD)}{KT(BCD/A)}$	$F_{\alpha;db(ACD);db(BCD/A)}$

### Model 12. Faktor C D acak & A B tetap

**Tabel 73 Anava Model 12 (Faktor C D acak & A B tetap)**

SV	Df	Fhitung	Ftabel
C	c-1=1	$F_{hitung}(C) = \frac{KT(C)}{KT(CD)}$	$F_{\alpha;db(C);db(CD)}$
D	d-1=1	$F_{hitung}(D) = \frac{KT(D)}{KT(CD)}$	$F_{\alpha;db(D);db(CD)}$
AC	(a-1)(c-1)=1	$F_{hitung}(AC) = \frac{KT(AC)}{KT(ACD)}$	$F_{\alpha;db(AC);db(ACD)}$
AD	(a-1)(d-1)=1	$F_{hitung}(AD) = \frac{KT(AD)}{KT(ACD)}$	$F_{\alpha;db(AD);db(ACD)}$
CD	(c-1)(d-1)=1	$F_{hitung}(CD) = \frac{KT(CD)}{KT(R/ABCD)}$	$F_{\alpha;db(CD);db(R/ABCD)}$
ACD	(a-1)(c-1)(d-1)=1	$F_{hitung}(ACD) = \frac{KT(ACD)}{KT(R/ABCD)}$	$F_{\alpha;db(ACD);db(R/ABCD)}$

### Model 13. Faktor A acak & B C D tetap

**Tabel 74 Anava Model 13 (Faktor A acak & B C D tetap)**

SV	Df	Fhitung	Ftabel
A	a-1=1	$F_{hitung}(A) = \frac{KT(A)}{KT(R/ABCD)}$	$F_{\alpha;db(A);db(R/ABCD)}$
C	c-1=1	$F_{hitung}(C) = \frac{KT(C)}{KT(AC)}$	$F_{\alpha;db(C);db(AC)}$
D	d-1=1	$F_{hitung}(D) = \frac{KT(D)}{KT(AD)}$	$F_{\alpha;db(D);db(AD)}$
AC	(a-1)(c-1)=1	$F_{hitung}(AC) = \frac{KT(AC)}{KT(R/ABCD)}$	$F_{\alpha;db(AC);db(R/ABCD)}$
AD	(a-1)(d-1)=1	$F_{hitung}(AD) = \frac{KT(AD)}{KT(R/ABCD)}$	$F_{\alpha;db(AD);db(R/ABCD)}$
CD	(c-1)(d-1)=1	$F_{hitung}(CD) = \frac{KT(CD)}{KT(ACD)}$	$F_{\alpha;db(CD);db(ACD)}$
ACD	(a-1)(c-1)(d-1)=1	$F_{hitung}(ACD) = \frac{KT(ACD)}{KT(R/ABCD)}$	$F_{\alpha;db(ACD);db(R/ABCD)}$

### Model 14. Faktor B acak & A C D tetap

**Tabel 75 Anava Model 14 (Faktor B acak & A C D tetap)**

SV	Df	Fhitung	Ftabel
A	a-1=1	$F_{hitung}(A) = \frac{KT(A)}{KT(B/A)}$	$F_{\alpha;db(A);db(B/A)}$
C	c-1=1	$F_{hitung}(C) = \frac{KT(C)}{KT(BC/A)}$	$F_{\alpha;db(C);db(BC/A)}$



SV	Df	Fhitung	Ftabel
D	d-1=1	$F_{hitung}(D) = \frac{KT(D)}{KT(BD/A)}$	$F_{\alpha;db(D);db(BD/A)}$
AC	(a-1)(c-1)=1	$F_{hitung}(AC) = \frac{KT(AC)}{KT(BC/A)}$	$F_{\alpha;db(AC);db(BC/A)}$
AD	(a-1)(d-1)=1	$F_{hitung}(AD) = \frac{KT(AD)}{KT(BD/A)}$	$F_{\alpha;db(AD);db(BD/A)}$
CD	(c-1)(d-1)=1	$F_{hitung}(CD) = \frac{KT(CD)}{KT(BCD/A)}$	$F_{\alpha;db(CD);db(BCD/A)}$
ACD	(a-1)(c-1)(d-1)=1	$F_{hitung}(ACD) = \frac{KT(ACD)}{KT(BCD/A)}$	$F_{\alpha;db(ACD);db(BCD/A)}$

### Model 15. Faktor C acak & A B D tetap

**Tabel 76 Anava Model 15 (Faktor C acak & A B D tetap)**

SV	Df	Fhitung	Ftabel
A	a-1=1	$F_{hitung}(A) = \frac{KT(A)}{KT(AC)}$	$F_{\alpha;db(A);db(AC)}$
C	c-1=1	$F_{hitung}(C) = \frac{KT(C)}{KT(R/ABCD)}$	$F_{\alpha;db(C);db(R/ABCD)}$
D	d-1=1	$F_{hitung}(D) = \frac{KT(D)}{KT(CD)}$	$F_{\alpha;db(D);db(CD)}$
AC	(a-1)(c-1)=1	$F_{hitung}(AC) = \frac{KT(AC)}{KT(R/ABCD)}$	$F_{\alpha;db(AC);db(R/ABCD)}$
AD	(a-1)(d-1)=1	$F_{hitung}(AD) = \frac{KT(AD)}{KT(ACD)}$	$F_{\alpha;db(AD);db(ACD)}$
CD	(c-1)(d-1)=1	$F_{hitung}(CD) = \frac{KT(CD)}{KT(R/ABCD)}$	$F_{\alpha;db(CD);db(R/ABCD)}$
ACD	(a-1)(c-1)(d-1)=1	$F_{hitung}(ACD) = \frac{KT(ACD)}{KT(R/ABCD)}$	$F_{\alpha;db(ACD);db(R/ABCD)}$

### Model 16. Faktor D acak & A B C tetap

**Tabel 77 Anava Model 16 (Faktor D acak & A B C tetap)**

SV	Df	Fhitung	Ftabel
A	a-1=1	$F_{hitung}(A) = \frac{KT(A)}{KT(AD)}$	$F_{\alpha;db(A);db(AD)}$
C	c-1=1	$F_{hitung}(C) = \frac{KT(C)}{KT(CD)}$	$F_{\alpha;db(C);db(CD)}$
D	d-1=1	$F_{hitung}(D) = \frac{KT(D)}{KT(R/ABCD)}$	$F_{\alpha;db(D);db(R/ABCD)}$

SV	Df	Fhitung	Ftabel
AC	$(a-1)(c-1)=1$	$F_{hitung}(AC) = \frac{KT(AC)}{KT(ACD)}$	$F_{\alpha;db(AC);db(ACD)}$
AD	$(a-1)(d-1)=1$	$F_{hitung}(AD) = \frac{KT(AD)}{KT(R/ABCD)}$	$F_{\alpha;db(AD);db(R/ABCD)}$
CD	$(c-1)(d-1)=1$	$F_{hitung}(CD) = \frac{KT(CD)}{KT(R/ABCD)}$	$F_{\alpha;db(CD);db(R/ABCD)}$
ACD	$(a-1)(c-1)(d-1)=1$	$F_{hitung}(ACD) = \frac{KT(ACD)}{KT(R/ABCD)}$	$F_{\alpha;db(ACD);db(R/ABCD)}$

## BAB V

### DIAGRAM BLOK DENGAN TERDAPAT KETERSARANGAN PADA FAKTOR UTAMA DAN TERDAPAT *REPEATED MEASUREMENT*

Tipe diagram blok yang terakhir ini memiliki paling banyak kemungkinan model. Ini karena pengaruh kondisi faktor utama yang tersarang, yaitu bisa 1 atau 2 atau 3 faktor utama yang tersarang dan terdapat *Repeated Measurement* sehingga memungkinkan ditemukan lebih banyak lagi model diagram blok dengan sumber variansi yang berbeda. Sebagian Model-model diagram blok nya adalah sebagai berikut:

**Tabel 78 Diagram Blok Model 1 B tersarang A & R tersarang di C dan R tersarang di D**

		A1		A2	
		B1	B2	B3	B4
C1	D1	R1-R3	R1-R3	R1-R3	R1-R3
	D2	R4-R6	R4-R6	R4-R6	R4-R6
C2	D1	R7-R9	R7-R9	R7-R9	R7-R9
	D2	R10-R12	R10-R12	R10-R12	R10-R12

Untuk mempermudah menentukan berbagai kemungkinan diagram blok, maka diagram blok nya ditrasformasi menjadi seperti tabel di bawah ini, dengan catatan bahwa makna tabelnya sama.

**Tabel 79 Diagram Blok Model 1 B tersarang A & R tersarang di C dan R tersarang di D**

A1								A2							
B1				B2				B3				B4			
C1		C2		C1		C2		C1		C2		C1		C2	
D1	D2	D1	D2	D1	D2	D1	D2	D1	D2	D1	D2	D1	D2	D1	D2
R1-R3	R4-R6	R7-R9	R10-R12	R1-R3	R4-R6	R7-R9	R10-R12	R1-R3	R4-R6	R7-R9	R10-R12	R1-R3	R4-R6	R7-R9	R10-R12

**Tabel 80 Diagram Blok Model 2 C tersarang B & R tersarang di C dan R tersarang di D**

A1								A2							
B1				B2				B1				B2			
C1		C2		C3		C4		C1		C2		C3		C4	
D1	D2	D1	D2	D1	D2	D1	D2	D1	D2	D1	D2	D1	D2	D1	D2
R1-R3	R4-R6	R7-R9	R10-R12	R1-R3	R4-R6	R7-R9	R10-R12	R1-R3	R4-R6	R7-R9	R10-R12	R1-R3	R4-R6	R7-R9	R10-R12

**Tabel 81 Diagram Blok Model 3 C tersarang A dan C tersarang B & R tersarang di C dan R tersarang di D**

A1								A2							
B1				B2				B1				B2			
C1		C2		C3		C4		C5		C6		C7		C8	
D1	D2	D1	D2	D1	D2	D1	D2	D1	D2	D1	D2	D1	D2	D1	D2
R1-R3	R4-R6	R7-R9	R10-R12	R1-R3	R4-R6	R7-R9	R10-R12	R1-R3	R4-R6	R7-R9	R10-R12	R1-R3	R4-R6	R7-R9	R10-R12

**Tabel 82 Diagram Blok Model 4 D tersarang C & R tersarang di C dan R tersarang di D**

A1								A2							
B1				B2				B1				B2			
C1		C2		C1		C2		C1		C2		C1		C2	
D1	D2	D3	D4	D1	D2	D3	D4	D1	D2	D3	D4	D1	D2	D3	D4
R1- R3	R4- R6	R7- R9	R10- R12	R1- R3	R4- R6	R7- R9	R10- R12	R1- R3	R4- R6	R7- R9	R10- R12	R1- R3	R4- R6	R7- R9	R10- R12

**Tabel 83 Diagram Blok Model 5 D tersarang C dan D tersarang B & R tersarang di C dan R tersarang di D**

A1								A2							
B1				B2				B1				B2			
C1		C2		C1		C2		C1		C2		C1		C2	
D1	D2	D3	D4	D5	D6	D7	D8	D1	D2	D3	D4	D5	D6	D7	D8
R1- R3	R4- R6	R7- R9	R10- R12	R1- R3	R4- R6	R7- R9	R10- R12	R1- R3	R4- R6	R7- R9	R10- R12	R1- R3	R4- R6	R7- R9	R10- R12

**Tabel 84 Diagram Blok Model 6 D tersarang A, D tersarang B, dan D tersarang C & R tersarang di C dan R tersarang di D**

A1								A2							
B1				B2				B1				B2			
C1		C2		C1		C2		C1		C2		C1		C2	
D1	D2	D3	D4	D5	D6	D7	D8	D9	D10	D11	D12	D13	D14	D15	D16
R1- R3	R4- R6	R7- R9	R10- R12	R1- R3	R4- R6	R7- R9	R10- R12	R1- R3	R4- R6	R7- R9	R10- R12	R1- R3	R4- R6	R7- R9	R10- R12

**Tabel 85 Diagram Blok Model 7 B tersarang A dan C tersarang B & R tersarang di C dan R tersarang di D**

A1								A2							
B1				B2				B3				B4			
C1		C2		C3		C4		C1		C2		C3		C4	
D1	D2	D1	D2	D1	D2	D1	D2	D1	D2	D1	D2	D1	D2	D1	D2
R1- R3	R4- R6	R7- R9	R10- R12	R1- R3	R4- R6	R7- R9	R10- R12	R1- R3	R4- R6	R7- R9	R10- R12	R1- R3	R4- R6	R7- R9	R10- R12

**Tabel 86 Diagram Blok Model 8 B tersarang A,C tersarang B, dan C tersarang A & R tersarang di C dan R tersarang di D**

A1								A2							
B1				B2				B3				B4			
C1		C2		C3		C4		C5		C6		C7		C8	
D1	D2	D1	D2	D1	D2	D1	D2	D1	D2	D1	D2	D1	D2	D1	D2
R1- R3	R4- R6	R7- R9	R10- R12	R1- R3	R4- R6	R7- R9	R10- R12	R1- R3	R4- R6	R7- R9	R10- R12	R1- R3	R4- R6	R7- R9	R10- R12

**Tabel 87 Diagram Blok Model 9 B tersarang di A, D tersarang di B, dan D tersarang di A & R tersarang di C dan R tersarang di D**

A1								A2							
B1				B2				B3				B4			
C1		C2		C1		C2		C1		C2		C1		C2	
D1	D2	D3	D4	D5	D6	D7	D8	D1	D2	D3	D4	D5	D6	D7	D8
R1- R3	R4- R6	R7- R9	R10- R12	R1- R3	R4- R6	R7- R9	R10- R12	R1- R3	R4- R6	R7- R9	R10- R12	R1- R3	R4- R6	R7- R9	R10- R12

**Tabel 88 Diagram Blok Model 10 B tersarang di A, D tersarang di C, D tersarang di B, dan D tersarang di A & R tersarang di C dan R tersarang di D**

A1								A2							
B1				B2				B3				B4			
C1		C2		C1		C2		C1		C2		C1		C2	
D1	D2	D3	D4	D5	D6	D7	D8	D9	D10	D11	D12	D13	D14	D15	D16
R1- R3	R4- R6	R7- R9	R10- R12	R1- R3	R4- R6	R7- R9	R10- R12	R1- R3	R4- R6	R7- R9	R10- R12	R1- R3	R4- R6	R7- R9	R10- R12

**Tabel 89 Diagram Blok Model 11 C tersarang di B dan D tersarang di C & R tersarang di C dan R tersarang di D**

A1								A2							
B1				B2				B1				B2			
C1		C2		C3		C4		C1		C2		C3		C4	
D1	D2	D3	D4	D1	D2	D3	D4	D1	D2	D3	D4	D1	D2	D3	D4
R1- R3	R4- R6	R7- R9	R10- R12	R1- R3	R4- R6	R7- R9	R10- R12	R1- R3	R4- R6	R7- R9	R10- R12	R1- R3	R4- R6	R7- R9	R10- R12

**Tabel 90 Diagram Blok Model 12 C tersarang di B, D tersarang di C, dan D tersarang di B & R tersarang di C dan R tersarang di D**

A1								A2							
B1				B2				B1				B2			
C1		C2		C3		C4		C1		C2		C3		C4	
D1	D2	D3	D4	D5	D6	D7	D8	D1	D2	D3	D4	D5	D6	D7	D8
R1- R3	R4- R6	R7- R9	R10- R12	R1- R3	R4- R6	R7- R9	R10- R12	R1- R3	R4- R6	R7- R9	R10- R12	R1- R3	R4- R6	R7- R9	R10- R12

**Tabel 91 Diagram Blok Model 13 C tersarang di B, D tersarang di C, D tersarang di B, dan D tersarang di A & R tersarang di C dan R tersarang di D**

A1								A2							
B1				B2				B1				B2			
C1		C2		C3		C4		C1		C2		C3		C4	
D1	D2	D3	D4	D5	D6	D7	D8	D9	D10	D11	D12	D13	D14	D15	D8
R1- R3	R4- R6	R7- R9	R10- R12	R1- R3	R4- R6	R7- R9	R10- R12	R1- R3	R4- R6	R7- R9	R10- R12	R1- R3	R4- R6	R7- R9	R10- R12

**Tabel 92 Diagram Blok Model 14 C tersarang di A, C tersarang di B, dan D tersarang di C & R tersarang di C dan R tersarang di D**

A1								A2							
B1				B2				B3				B4			
C1		C2		C3		C4		C5		C6		C7		C8	
D1	D2	D3	D4	D1	D2	D3	D4	D1	D2	D3	D4	D1	D2	D3	D4
R1- R3	R4- R6	R7- R9	R10- R12	R1- R3	R4- R6	R7- R9	R10- R12	R1- R3	R4- R6	R7- R9	R10- R12	R1- R3	R4- R6	R7- R9	R10- R12

**Tabel 93 Diagram Blok Model 15 C tersarang di A, C tersarang di B, D tersarang di C, dan D tersarang di B & R tersarang di C dan R tersarang di D**

A1								A2							
B1				B2				B3				B4			
C1		C2		C3		C4		C5		C6		C7		C8	
D1	D2	D3	D4	D5	D6	D7	D8	D1	D2	D3	D4	D5	D6	D7	D8
R1- R3	R4- R6	R7- R9	R10- R12	R1- R3	R4- R6	R7- R9	R10- R12	R1- R3	R4- R6	R7- R9	R10- R12	R1- R3	R4- R6	R7- R9	R10- R12

**Tabel 94 Diagram Blok Model 16 C tersarang di A, C tersarang di B, D tersarang di C, D tersarang di B, dan D tersarang di A & R tersarang di C dan R tersarang di D**

A1								A2							
B1				B2				B3				B4			
C1		C2		C3		C4		C5		C6		C7		C8	
D1	D2	D3	D4	D5	D6	D7	D8	D9	D10	D11	D12	D13	D14	D15	D16
R1- R3	R4- R6	R7- R9	R10- R12	R1- R3	R4- R6	R7- R9	R10- R12	R1- R3	R4- R6	R7- R9	R10- R12	R1- R3	R4- R6	R7- R9	R10- R12

Beberapa model diagram blok di atas barulah sebagian model saja, dan masih banyak model diagram blok yang lainnya yang belum disampaikan oleh penulis pada bab ini. Silahkan pembaca menentukan sendiri kemungkinan lainnya dengan 3 faktor utama yang tersarang sekaligus, yaitu faktor B, C, dan D tersarang pada A dan dengan berbagai kombinasi R yang berbeda.

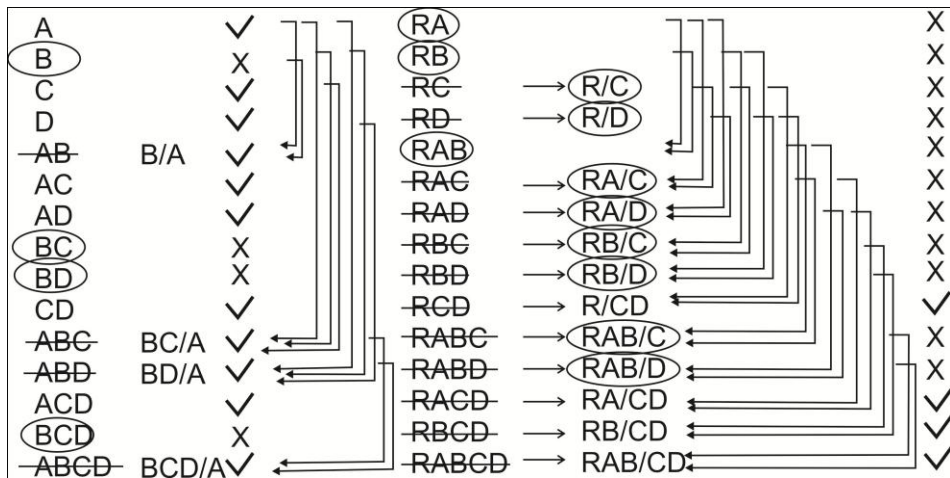

**Gambar 9 Menentukan Sumber Variansi Model 1 Terdapat Ketersarangan pada Faktor Utama dan Terdapat *Repeated Measurement***

Selanjutnya pembaca bisa menentukan SV untuk model yang lainnya. Dengan mengikuti alur atau langkah-langkah yang telah disajikan oleh penulis.

Kita ketahui bahwa setiap model diagram blok menghasilkan 16 model tabel ANAVA. Adapun kombinasinya adalah sebagai berikut:

**Gambar 10 Berbagai Kemungkinan Tabel Anava Terdapat Ketersarangan pada Faktor Utama dan Terdapat *Repeated Measurement***

Model	Faktor A	Faktor B	Faktor C	Faktor D
Model 1	A	A	A	A
Model 2	T	T	T	T
Model 3	A	A	A	T
Model 4	A	A	T	A
Model 5	A	T	A	A
Model 6	T	A	A	A
Model 7	A	A	T	T
Model 8	A	T	A	T
Model 9	T	A	A	T
Model 10	A	T	T	A
Model 11	T	A	T	A
Model 12	T	A	A	T
Model 13	A	T	T	T
Model 14	T	A	T	T
Model 15	T	T	A	T

Model	Faktor A	Faktor B	Faktor C	Faktor D
Model 16	T	T	T	A

Keterangan :

A : Acak

T : Tetap

Dari 16 model diagram blok tersebut kemungkinan bisa ditemukan  $16 \times 16 = 256$  model tabel ANAVA. Akan tetapi, kali ini hanya akan ditentukan berbagai model tabel ANAVA untuk model diagram blok yang pertama. Selebihnya bisa dicoba dicari sendiri oleh para pembaca. Selamat mencoba

Menentukan tabel ANAVA untuk model tabel ANAVA yang pertama

### Model 1. Faktor A B C D semua acak

Langkah pertama

SV	EMS
A	$\sigma^2_{RAB/CD} + a\sigma^2_{RB/CD} + b\sigma^2_{RA/CD} + ab\sigma^2_{R/CD} + r\sigma^2_{BCD/A} + rc\sigma^2_{BD/A} + rd\sigma^2_{BC/A} + rcd\sigma^2_{B/A} + rb\sigma^2_{ACD} + rab\sigma^2_{CD} + rbc\sigma^2_{AD} + rbd\sigma^2_{AC} + rabc\sigma^2_D + rabd\sigma^2_C + rbcd\sigma^2_A$
C	$\sigma^2_{RAB/CD} + a\sigma^2_{RB/CD} + b\sigma^2_{RA/CD} + ab\sigma^2_{R/CD} + r\sigma^2_{BCD/A} + rc\sigma^2_{BD/A} + rd\sigma^2_{BC/A} + rcd\sigma^2_{B/A} + rb\sigma^2_{ACD} + rab\sigma^2_{CD} + rbc\sigma^2_{AD} + rbd\sigma^2_{AC} + rabc\sigma^2_D + rabd\sigma^2_C$
D	$\sigma^2_{RAB/CD} + a\sigma^2_{RB/CD} + b\sigma^2_{RA/CD} + ab\sigma^2_{R/CD} + r\sigma^2_{BCD/A} + rc\sigma^2_{BD/A} + rd\sigma^2_{BC/A} + rcd\sigma^2_{B/A} + rb\sigma^2_{ACD} + rab\sigma^2_{CD} + rbc\sigma^2_{AD} + rbd\sigma^2_{AC} + rabc\sigma^2_D$
AC	$\sigma^2_{RAB/CD} + a\sigma^2_{RB/CD} + b\sigma^2_{RA/CD} + ab\sigma^2_{R/CD} + r\sigma^2_{BCD/A} + rc\sigma^2_{BD/A} + rd\sigma^2_{BC/A} + rcd\sigma^2_{B/A} + rb\sigma^2_{ACD} + rab\sigma^2_{CD} + rbc\sigma^2_{AD} + rbd\sigma^2_{AC}$
AD	$\sigma^2_{RAB/CD} + a\sigma^2_{RB/CD} + b\sigma^2_{RA/CD} + ab\sigma^2_{R/CD} + r\sigma^2_{BCD/A} + rc\sigma^2_{BD/A} + rd\sigma^2_{BC/A} + rcd\sigma^2_{B/A} + rb\sigma^2_{ACD} + rab\sigma^2_{CD} + rbc\sigma^2_{AD}$
CD	$\sigma^2_{RAB/CD} + a\sigma^2_{RB/CD} + b\sigma^2_{RA/CD} + ab\sigma^2_{R/CD} + r\sigma^2_{BCD/A} + rc\sigma^2_{BD/A} + rd\sigma^2_{BC/A} + rcd\sigma^2_{B/A} + rb\sigma^2_{ACD} + rab\sigma^2_{CD}$
ACD	$\sigma^2_{RAB/CD} + a\sigma^2_{RB/CD} + b\sigma^2_{RA/CD} + ab\sigma^2_{R/CD} + r\sigma^2_{BCD/A} + rc\sigma^2_{BD/A} + rd\sigma^2_{BC/A} + rcd\sigma^2_{B/A} + rb\sigma^2_{ACD}$
B/A	$\sigma^2_{RAB/CD} + a\sigma^2_{RB/CD} + b\sigma^2_{RA/CD} + ab\sigma^2_{R/CD} + r\sigma^2_{BCD/A} + rc\sigma^2_{BD/A} + rd\sigma^2_{BC/A} + rcd\sigma^2_{B/A}$





SV	EMS
RB/CD	$\sigma^2_{RAB/CD} + a\sigma^2_{RB/CD}$
RAB/CD	$\sigma^2_{RAB/CD}$

Diagram blok dengan kombinasi Faktor A B C D semua acak tidak memiliki tabel ANAVA dan tidak bisa digunakan dalam desain penelitian

### Model 2. Faktor A B C D semua tetap

langkah pertama

SV	EMS
A	$\sigma^2_{RAB/CD} + a\sigma^2_{RB/CD} + b\sigma^2_{RA/CD} + ab\sigma^2_{R/CD} + r\sigma^2_{BCD/A} + rc\sigma^2_{BD/A} + rd\sigma^2_{BC/A} + rcd\sigma^2_{B/A} + rb\theta^2_{ACD} + rab\theta^2_{CD} + rbc\theta^2_{AD} + rbd\theta^2_{AC} + rabc\theta^2_D + rabd\theta^2_C + rbcd\theta^2_A$
C	$\sigma^2_{RAB/CD} + a\sigma^2_{RB/CD} + b\sigma^2_{RA/CD} + ab\sigma^2_{R/CD} + r\sigma^2_{BCD/A} + rc\sigma^2_{BD/A} + rd\sigma^2_{BC/A} + rcd\sigma^2_{B/A} + rb\theta^2_{ACD} + rab\theta^2_{CD} + rbc\theta^2_{AD} + rbd\theta^2_{AC} + rabc\theta^2_D + rabd\theta^2_C$
D	$\sigma^2_{RAB/CD} + a\sigma^2_{RB/CD} + b\sigma^2_{RA/CD} + ab\sigma^2_{R/CD} + r\sigma^2_{BCD/A} + rc\sigma^2_{BD/A} + rd\sigma^2_{BC/A} + rcd\sigma^2_{B/A} + rb\theta^2_{ACD} + rab\theta^2_{CD} + rbc\theta^2_{AD} + rbd\theta^2_{AC} + rabc\theta^2_D$
AC	$\sigma^2_{RAB/CD} + a\sigma^2_{RB/CD} + b\sigma^2_{RA/CD} + ab\sigma^2_{R/CD} + r\sigma^2_{BCD/A} + rc\sigma^2_{BD/A} + rd\sigma^2_{BC/A} + rcd\sigma^2_{B/A} + rb\theta^2_{ACD} + rab\theta^2_{CD} + rbc\theta^2_{AD} + rbd\theta^2_{AC}$
AD	$\sigma^2_{RAB/CD} + a\sigma^2_{RB/CD} + b\sigma^2_{RA/CD} + ab\sigma^2_{R/CD} + r\sigma^2_{BCD/A} + rc\sigma^2_{BD/A} + rd\sigma^2_{BC/A} + rcd\sigma^2_{B/A} + rb\theta^2_{ACD} + rab\theta^2_{CD} + rbc\theta^2_{AD}$
CD	$\sigma^2_{RAB/CD} + a\sigma^2_{RB/CD} + b\sigma^2_{RA/CD} + ab\sigma^2_{R/CD} + r\sigma^2_{BCD/A} + rc\sigma^2_{BD/A} + rd\sigma^2_{BC/A} + rcd\sigma^2_{B/A} + rb\theta^2_{ACD} + rab\theta^2_{CD}$
ACD	$\sigma^2_{RAB/CD} + a\sigma^2_{RB/CD} + b\sigma^2_{RA/CD} + ab\sigma^2_{R/CD} + r\sigma^2_{BCD/A} + rc\sigma^2_{BD/A} + rd\sigma^2_{BC/A} + rcd\sigma^2_{B/A} + rb\theta^2_{ACD}$
B/A	$\sigma^2_{RAB/CD} + a\sigma^2_{RB/CD} + b\sigma^2_{RA/CD} + ab\sigma^2_{R/CD} + r\sigma^2_{BCD/A} + rc\sigma^2_{BD/A} + rd\sigma^2_{BC/A} + rcd\sigma^2_{B/A}$
BC/A	$\sigma^2_{RAB/CD} + a\sigma^2_{RB/CD} + b\sigma^2_{RA/CD} + ab\sigma^2_{R/CD} + r\sigma^2_{BCD/A} + rc\sigma^2_{BD/A} + rd\sigma^2_{BC/A}$
BD/A	$\sigma^2_{RAB/CD} + a\sigma^2_{RB/CD} + b\sigma^2_{RA/CD} + ab\sigma^2_{R/CD} + r\sigma^2_{BCD/A} + rc\sigma^2_{BD/A}$
BCD/A	$\sigma^2_{RAB/CD} + a\sigma^2_{RB/CD} + b\sigma^2_{RA/CD} + ab\sigma^2_{R/CD} + r\sigma^2_{BCD/A}$
R/CD	$\sigma^2_{RAB/CD} + a\sigma^2_{RB/CD} + b\sigma^2_{RA/CD} + ab\sigma^2_{R/CD}$
RA/CD	$\sigma^2_{RAB/CD} + a\sigma^2_{RB/CD} + b\sigma^2_{RA/CD}$
RB/CD	$\sigma^2_{RAB/CD} + a\sigma^2_{RB/CD}$
RAB/CD	$\sigma^2_{RAB/CD}$



SV	EMS
C	$\sigma^2_{RAB/CD} + a\sigma^2_{RB/CD} + b\sigma^2_{RA/CD} + ab\sigma^2_{R/CD} + r\sigma^2_{BCD/A} + rc\sigma^2_{BD/A} + rd\sigma^2_{BC/A} + rcd\sigma^2_{B/A} + rb\theta^2_{ACD} + rab\theta^2_{CD} + rbc\theta^2_{AD} + rbd\theta^2_{AC} + rabc\theta^2_D + rabd\theta^2_C$
D	$\sigma^2_{RAB/CD} + a\sigma^2_{RB/CD} + b\sigma^2_{RA/CD} + ab\sigma^2_{R/CD} + r\sigma^2_{BCD/A} + rc\sigma^2_{BD/A} + rd\sigma^2_{BC/A} + rcd\sigma^2_{B/A} + rb\theta^2_{ACD} + rab\theta^2_{CD} + rbc\theta^2_{AD} + rbd\theta^2_{AC} + rabc\theta^2_D$
AC	$\sigma^2_{RAB/CD} + a\sigma^2_{RB/CD} + b\sigma^2_{RA/CD} + ab\sigma^2_{R/CD} + r\sigma^2_{BCD/A} + rc\sigma^2_{BD/A} + rd\sigma^2_{BC/A} + rcd\sigma^2_{B/A} + rb\theta^2_{ACD} + rab\theta^2_{CD} + rbc\theta^2_{AD} + rbd\theta^2_{AC}$
AD	$\sigma^2_{RAB/CD} + a\sigma^2_{RB/CD} + b\sigma^2_{RA/CD} + ab\sigma^2_{R/CD} + r\sigma^2_{BCD/A} + rc\sigma^2_{BD/A} + rd\sigma^2_{BC/A} + rcd\sigma^2_{B/A} + rb\theta^2_{ACD} + rab\theta^2_{CD} + rbc\theta^2_{AD}$
CD	$\sigma^2_{RAB/CD} + a\sigma^2_{RB/CD} + b\sigma^2_{RA/CD} + ab\sigma^2_{R/CD} + r\sigma^2_{BCD/A} + rc\sigma^2_{BD/A} + rd\sigma^2_{BC/A} + rcd\sigma^2_{B/A} + rb\theta^2_{ACD} + rab\theta^2_{CD}$
ACD	$\sigma^2_{RAB/CD} + a\sigma^2_{RB/CD} + b\sigma^2_{RA/CD} + ab\sigma^2_{R/CD} + r\sigma^2_{BCD/A} + rc\sigma^2_{BD/A} + rd\sigma^2_{BC/A} + rcd\sigma^2_{B/A} + rb\theta^2_{ACD}$
B/A	$\sigma^2_{RAB/CD} + a\sigma^2_{RB/CD} + b\sigma^2_{RA/CD} + ab\sigma^2_{R/CD} + r\sigma^2_{BCD/A} + rc\sigma^2_{BD/A} + rd\sigma^2_{BC/A} + rcd\sigma^2_{B/A}$
BC/A	$\sigma^2_{RAB/CD} + a\sigma^2_{RB/CD} + b\sigma^2_{RA/CD} + ab\sigma^2_{R/CD} + r\sigma^2_{BCD/A} + rc\sigma^2_{BD/A} + rd\sigma^2_{BC/A}$
BD/A	$\sigma^2_{RAB/CD} + a\sigma^2_{RB/CD} + b\sigma^2_{RA/CD} + ab\sigma^2_{R/CD} + r\sigma^2_{BCD/A} + rc\sigma^2_{BD/A}$
BCD/A	$\sigma^2_{RAB/CD} + a\sigma^2_{RB/CD} + b\sigma^2_{RA/CD} + ab\sigma^2_{R/CD} + r\sigma^2_{BCD/A}$
R/CD	$\sigma^2_{RAB/CD} + a\sigma^2_{RB/CD} + b\sigma^2_{RA/CD} + ab\sigma^2_{R/CD}$
RA/CD	$\sigma^2_{RAB/CD} + a\sigma^2_{RB/CD} + b\sigma^2_{RA/CD}$
RB/CD	$\sigma^2_{RAB/CD} + a\sigma^2_{RB/CD}$
RAB/CD	$\sigma^2_{RAB/CD}$

**Tabel 95 Anava Model 2 (Faktor A B C D semua tetap)**

SV	Df	Fhitung	Ftabel
A	(a-1) = 1	$F_{hitung}(A) = \frac{KT(A)}{KT(RA/CD)}$	$F_{\alpha; db(A); db(RA/CD)}$
C	(c-1) = 1	$F_{hitung}(C) = \frac{KT(C)}{KT(R/CD)}$	$F_{\alpha; db(C); db(R/CD)}$
D	(d-1) = 1	$F_{hitung}(D) = \frac{KT(D)}{KT(R/CD)}$	$F_{\alpha; db(C); db(R/CD)}$
AC	(a-1)(c-1) = 1	$F_{hitung}(AC) = \frac{KT(AC)}{KT(RA/CD)}$	$F_{\alpha; db(AC); db(RA/CD)}$
AD	(a-1)(d-1) = 1	$F_{hitung}(AD) = \frac{KT(AD)}{KT(RA/CD)}$	$F_{\alpha; db(AD); db(RA/CD)}$
CD	(c-1)(d-1) = 1	$F_{hitung}(CD) = \frac{KT(CD)}{KT(R/CD)}$	$F_{\alpha; db(CD); db(R/CD)}$

SV	Df	Fhitung	Ftabel
ACD	$(a-1)(c-1)(d-1) = 1$	$F_{hitung}(ACD) = \frac{KT(ACD)}{KT(RA/CD)}$	$F_{\alpha;db(ACD);db(RA/CD)}$

### Model 3. Faktor A tetap, B C D acak

Diagram blok dengan kombinasi Faktor A tetap, B C D acak tidak memiliki tabel ANAVA dan tidak bisa digunakan dalam desain penelitian

### Model 4. Faktor B tetap, A C D acak

**Tabel 96 Anava Model 4 (Faktor B tetap, A C D acak)**

SV	Df	Fhitung	Ftabel
AC	$(a-1)(c-1) = 1$	$F_{hitung}(AC) = \frac{KT(AC)}{KT(ACD)}$	$F_{\alpha;db(AC);db(ACD)}$
AD	$(a-1)(d-1) = 1$	$F_{hitung}(AD) = \frac{KT(AD)}{KT(ACD)}$	$F_{\alpha;db(AD);db(ACD)}$
ACD	$(a-1)(c-1)(d-1) = 1$	$F_{hitung}(ACD) = \frac{KT(ACD)}{KT(RA/CD)}$	$F_{\alpha;db(ACD);db(RA/CD)}$

### Model 5. Faktor C tetap, ABD acak

Diagram blok dengan kombinasi Faktor C tetap, ABD acak tidak memiliki tabel ANAVA dan tidak bisa digunakan dalam desain penelitian

### Model 6. Faktor D tetap, ABC acak

Diagram blok dengan kombinasi Faktor D tetap, ABC acak tidak memiliki tabel ANAVA dan tidak bisa digunakan dalam desain penelitian

### Model 7. Faktor AB tetap, CD acak

**Tabel 97 Anava Model 7 (Faktor AB tetap, CD acak)**

SV	Df	Fhitung	Ftabel
C	(c-1) = 1	$F_{hitung}(C) = \frac{KT(C)}{KT(CD)}$	$F_{\alpha;db(C);db(CD)}$
D	(d-1) = 1	$F_{hitung}(D) = \frac{KT(D)}{KT(CD)}$	$F_{\alpha;db(D);db(CD)}$
AC	(a-1)(c-1) = 1	$F_{hitung}(AC) = \frac{KT(AC)}{KT(ACD)}$	$F_{\alpha;db(AC);db(ACD)}$
AD	(a-1)(d-1) = 1	$F_{hitung}(AD) = \frac{KT(AD)}{KT(ACD)}$	$F_{\alpha;db(AD);db(ACD)}$
CD	(c-1)(d-1) = 1	$F_{hitung}(CD) = \frac{KT(CD)}{KT(R/CD)}$	$F_{\alpha;db(CD);db(R/CD)}$
ACD	(a-1)(c-1)(d-1) = 1	$F_{hitung}(ACD) = \frac{KT(ACD)}{KT(RA/CD)}$	$F_{\alpha;db(ACD);db(RA/CD)}$

### Model 8. Faktor AC tetap, B D acak

Diagram blok dengan kombinasi Faktor AC tetap, B D acak tidak memiliki tabel ANAVA dan tidak bisa digunakan dalam desain penelitian

### Model 9. Faktor B C tetap, A D acak

**Tabel 98 Anava Model 9 (Faktor B C tetap, A D acak)**

SV	Df	Fhitung	Ftabel
A	(a-1) = 1	$F_{hitung}(A) = \frac{KT(A)}{KT(AD)}$	$F_{\alpha;db(A);db(AD)}$
AC	(a-1)(c-1) = 1	$F_{hitung}(AC) = \frac{KT(AC)}{KT(ACD)}$	$F_{\alpha;db(AC);db(ACD)}$
AD	(a-1)(d-1) = 1	$F_{hitung}(AD) = \frac{KT(AD)}{KT(RA/CD)}$	$F_{\alpha;db(AD);db(RA/CD)}$
ACD	(a-1)(c-1)(d-1) = 1	$F_{hitung}(ACD) = \frac{KT(ACD)}{KT(RA/CD)}$	$F_{\alpha;db(ACD);db(RA/CD)}$

### Model 10. Faktor AD tetap, B C acak

Diagram blok dengan kombinasi Faktor AD tetap, B C acak tidak memiliki tabel ANAVA dan tidak bisa digunakan dalam desain penelitian

### Model 11. Faktor C D tetap, A B acak

Diagram blok dengan kombinasi Faktor C D tetap, A B acak tidak memiliki tabel ANAVA dan tidak bisa digunakan dalam desain penelitian

### Model 12. Faktor B D tetap, A C acak

**Tabel 99 Anava Model 12 (Faktor B D tetap, A C acak)**

SV	Df	Fhitung	Ftabel
A	(a-1) = 1	$F_{hitung}(A) = \frac{KT(A)}{KT(AC)}$	$F_{\alpha;db(A);db(AC)}$
AC	(a-1)(c-1) = 1	$F_{hitung}(AC) = \frac{KT(AC)}{KT(RA/CD)}$	$F_{\alpha;db(AC);db(RA/CD)}$
AD	(a-1)(d-1) = 1	$F_{hitung}(AD) = \frac{KT(AD)}{KT(ACD)}$	$F_{\alpha;db(AD);db(ACD)}$
ACD	(a-1)(c-1)(d-1) = 1	$F_{hitung}(ACD) = \frac{KT(ACD)}{KT(RA/CD)}$	$F_{\alpha;db(ACD);db(RA/CD)}$

### Model 13. Faktor A B C tetap, D acak

Tabel 100 Anava Model 13 (Faktor A B C tetap, D acak)

SV	Df	Fhitung	Ftabel
A	(a-1) = 1	$F_{hitung}(A) = \frac{KT(A)}{KT(AD)}$	$F_{\alpha;db(A);db(AD)}$
C	(c-1) = 1	$F_{hitung}(C) = \frac{KT(C)}{KT(CD)}$	$F_{\alpha;db(C);db(CD)}$
D	(d-1) = 1	$F_{hitung}(D) = \frac{KT(D)}{KT(R/CD)}$	$F_{\alpha;db(D);db(R/CD)}$
AC	(a-1)(c-1) = 1	$F_{hitung}(AC) = \frac{KT(AC)}{KT(ACD)}$	$F_{\alpha;db(AC);db(ACD)}$
AD	(a-1)(d-1) = 1	$F_{hitung}(AD) = \frac{KT(AD)}{KT(RA/CD)}$	$F_{\alpha;db(AD);db(RA/CD)}$
CD	(c-1)(d-1) = 1	$F_{hitung}(CD) = \frac{KT(CD)}{KT(R/CD)}$	$F_{\alpha;db(CD);db(R/CD)}$
ACD	(a-1)(c-1)(d-1) = 1	$F_{hitung}(ACD) = \frac{KT(ACD)}{KT(RA/CD)}$	$F_{\alpha;db(ACD);db(RA/CD)}$

### Model 14. Faktor A B D tetap, C acak

Tabel 101 Anava Model 14 (Faktor A B D tetap, C acak)

SV	Df	Fhitung	Ftabel
A	(a-1) = 1	$F_{hitung}(A) = \frac{KT(A)}{KT(AC)}$	$F_{\alpha;db(A);db(AC)}$
C	(c-1) = 1	$F_{hitung}(C) = \frac{KT(C)}{KT(R/CD)}$	$F_{\alpha;db(C);db(R/CD)}$
D	(d-1) = 1	$F_{hitung}(D) = \frac{KT(D)}{KT(CD)}$	$F_{\alpha;db(D);db(CD)}$
AC	(a-1)(c-1) = 1	$F_{hitung}(AC) = \frac{KT(AC)}{KT(RA/CD)}$	$F_{\alpha;db(AC);db(RA/CD)}$
AD	(a-1)(d-1) = 1	$F_{hitung}(AD) = \frac{KT(AD)}{KT(ACD)}$	$F_{\alpha;db(AD);db(ACD)}$

SV	Df	Fhitung	Ftabel
CD	$(c-1)(d-1) = 1$	$F_{hitung}(CD) = \frac{KT(CD)}{KT(R/CD)}$	$F_{\alpha;db(CD);db(R/CD)}$
ACD	$(a-1)(c-1)(d-1) = 1$	$F_{hitung}(ACD) = \frac{KT(ACD)}{KT(RA/CD)}$	$F_{\alpha;db(ACD);db(RA/CD)}$

### Model 15. Faktor A C D tetap, B acak

Diagram blok dengan kombinasi Faktor A C D tetap, B acak tidak memiliki tabel ANAVA dan tidak bisa digunakan dalam desain penelitian

### Model 16. Faktor B C D tetap, A acak

Tabel 102 Anava Model 16 (Faktor B C D tetap, A acak)

SV	Df	Fhitung	Ftabel
A	$(a-1) = 1$	$F_{hitung}(A) = \frac{KT(A)}{KT(RA/CD)}$	$F_{\alpha;db(A);db(RA/CD)}$
AC	$(a-1)(c-1) = 1$	$F_{hitung}(AC) = \frac{KT(AC)}{KT(RA/CD)}$	$F_{\alpha;db(AC);db(RA/CD)}$
AD	$(a-1)(d-1) = 1$	$F_{hitung}(AD) = \frac{KT(AD)}{KT(RA/CD)}$	$F_{\alpha;db(AD);db(RA/CD)}$
ACD	$(a-1)(c-1)(d-1) = 1$	$F_{hitung}(ACD) = \frac{KT(ACD)}{KT(RA/CD)}$	$F_{\alpha;db(ACD);db(RA/CD)}$

## DAFTAR PUSTAKA



- Budiyono.2003. *Metodologi Penelitian Pendidikan*. Surakarta: Sebelas Maret University Press.
- \_\_\_\_\_. 2009. *Statistika Untuk Penelitian*. Surakarta: Sebelas Maret University Press.
- Hanafiah, Kemas Ali. (2016). *Rancangan Percobaan Teori dan Aplikasi*. Rajagrafindo Persada: Jakarta
- Nely, I. M., Urip, T., Dwi C.N.A, & Martini. 2019. *Desain Faktorial*. Pacitan: LPPM STKIP PGRI Pacitan.
- Jaynes J., Ding, X., Xu, H., Wong, W. K., & Ho, C. M., (2012). Application of Fractional Factorial Design to Study Drug Combinations. *Wiley Online Library*. John Wiley & Sons, Ltd: New York.
- Kirk, Roger E. (1995). *Experimental Design: Procedures for the Behavioral Sciences*. Brooks/ Cole Publishing Company: USA.
- Mattjik, A. A. & Sumertajaya, I Made. (2013). *Perancangan Percobaan dengan Aplikasi SAS dan MINITAB*. IPB Press: Bogor.
- Nesari, Tanuja. (tth). *Applied Research Approaches: Background Paper*. IASTAM: India.
- Pais, M. S., Peretta, I. S., Yamanaka, K., & Pinto, E., R. (2014). Factorial Design Analysis Applied to The Performance of Parallel Evolutionary Algorithms. *Journal of The Brazilian Computer Society*. 20(6): 1-17.
- Santosa, Purbayu Budi & Ashari. (2005). *Analisis Statistik dengan Microsoft Excel & SPSS*. Andi: Yogyakarta.
- Steinberg, D. M., & Hunter, W. G. (1984). Experimental design: review and comment. *Technometrics* 26(2): 71–97
- Subana, Rahadi, S., Sudrajat. (2000). *Statistik Pendidikan*. Pustaka Setia: Bandung.
- Priyatno, Duwi. (2002). *Belajar Praktis Analisis Parametrik dan Non Parametrik dengan SPSS*. Gava Media: Yogyakarta.
- Tanujaya. Benidiktus. (2013). *Penelitian Percobaan*. PT Remaja Rosdakarya: Bandung.
- Wu, C. F. J., Hamada, M., & Joseph, V.R. (2009). *Experiments: Planning, Analysis and Parameter Design Optimization, (2nd edn)*. Wiley: New York.
- Zahran, Alyaa R., 2013. Two-Level Factorial Design with Circular Response: Model and Analysis. *Journal of Data Science* 11: 415-432.

## **Biodata Penulis**



**Nely Indra Meifiani, S.Si., M.Pd.**

Penulis adalah Dosen Program Studi Pendidikan Matematika di STKIP PGRI Pacitan sejak 2009 sampai saat ini 2018. Lulusan S1 Matematika UNY tahun 2008. Lulusan S2 Pendidikan Matematika UNY 2012. Saat ini Penulis konsentrasi kepakaran bidang Statistika. Pengampu mata kuliah Statistika Lanjut, Teori Peluang, Rancangan Percobaan, dan Statistika Non Parametrik. Sejak tahun 2012 Peneliti Aktif menjalankan Tri Dharma Perguruan Tinggi. Peneliti aktif dalam penelitian dan pengabdian baik mandiri, hibah internal, Pemda, maupun hibah dikti. peneliti Lolos Hibah dikti sejak tahun 2014. Yaitu PDP, KKN-PPM, dan PDU-PT. Penulis mulai aktif menulis artikel ilmiah yang dipublikasikan di jurnal nasional ber ISSN, menjadi peserta/ pemakalah temu ilmiah, seperti seminar nasional dan internasional, workshop, konferensi, diskusi ilmiah sejak tahun 2012. Penulis telah menghasilkan 5 buku ber-ISBN, yaitu "Pemberdayaan Masyarakat melalui Revitalisasi Potensi Sumber Daya Manusia pada Bidang Kesehatan, Ekonomi, Kewirausahaan, dan Kebencanaan" (Dialektika, Yogyakarta, 2016), "Teori Peluang" (Oase Pustaka Surakarta, 2015), "Studi Terhadap Pola Asuh Orang Tua, Kecemasan, dan Kepercayaan Diri" (Nuha Medika Yogyakarta, 2014), "Desain Faktorial : Buku Penunjang Rancangan Percobaan" (LPPM Press, 2018)". Selain itu peneliti adalah Relawan BPBD dalam bidang sosialisasi tentang kebencanaan di Lingkungan Sekolah dan Masyarakat.



**Urip Tisngati, M.Pd**

Penulis merupakan Pendidik di STKIP PGRI Pacitan. Penulis lulus S-1 Prodi Pendidikan Matematika (STKIP PGRI Pacitan-2004), S-2 Prodi Pendidikan Matematika (UNS-2011), dan sejak 2016 sedang menempuh studi lanjut S-3 pada Prodi Ilmu Pendidikan Konsentrasi Pendidikan Matematika (UNY). Sejak tahun 2011 penulis melakukan penelitian dan pengabdian, baik dana mandiri, Damandiri, Pemda, hibah internal, maupun hibah Dikti. Penelitian didanai Dikti berupa PDP-2x dan PDU-PT tahun 2018. Pada bidang PkM, didanai Dikti berupa IbM, KKN-PPM-3x, IbW-2x. Penulis aktif menjadi peserta/ pemakalah temu ilmiah, seperti seminar nasional dan internasional, workshop, konferensi, diskusi ilmiah sejak tahun 2012. Sejak tahun 2011, menulis artikel ilmiah dipublikasi di jurnal nasional ber ISSN, serta menghasilkan 6 buku ber-ISBN, yaitu "Implementasi Strategi Pembelajaran TTW Terintegrasi *Problem Possing*" (Nuha Medika Yogyakarta, 2014); "Studi Terhadap Pola Asuh Orang Tua, Kecemasan, dan Kepercayaan Diri" (Nuha Medika Yogyakarta, 2014) bersama Nely Indra Meifiani;

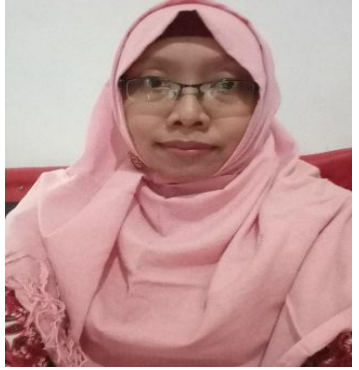
	<p>“Pedoman Pelaksanaan Kuliah Kerja Nyata Pembelajaran Pemberdayaan Masyarakat (KKN-PPM) STKIP PGRI Pacitan Tahun 2016” (LPPM Press STKIP PGRI Pacitan, 2016), “Pemberdayaan Masyarakat melalui Revitalisasi Potensi Sumber Daya Manusia pada Bidang Kesehatan, Ekonomi Kewirausahaan, dan Kebencanaan” (Dialektika, Yogyakarta, 2016), “Pengembangan Kurikulum Pendidikan Matematika” (Media Akademi, Yogyakarta, 2018),” Desain Faktorial: Buku Penunjang Rancangan Percobaan” (LPPM Press, 2018)”. Korespondensi penulis pada surel: <a href="mailto:ifedeoer@gmail.com">ifedeoer@gmail.com</a> atau <a href="mailto:uriptisngati@gmail.com">uriptisngati@gmail.com</a> Aktivitas penulis dapat dilihat pada link: <a href="http://ifedeoer.blogspot.com/">http://ifedeoer.blogspot.com/</a> dan <a href="http://urip-tisngati.blogspot.com/">http://urip-tisngati.blogspot.com/</a></p>
	<p><b>Dra. Martini, M.Pd.</b>  Penulis Lahir di Pacitan pada tahun 1965, menyelesaikan S-1 Prodi PPKn (IKIP PGRI Surabaya, 1991), S-2 Prodi PIPS (Univ. Kanjuruhan Malang, 2011). Penulis menjadi dosen tetap di STKIP PGRI Pacitan sejak 1991, menjadi pustakawan, Kaprodi Pendidikan Sejarah (2010-2016), Kabiro Kepegawaian (2017-sekarang). Penulis telah mendapat hibah dari Dikti berupa Penelitian Dosen Pemula (2014-2015), PDU-PT (2018), hibah pengabdian berupa Ipteks Bagi Masyarakat (2015). Penulis aktif mengikuti seminar, workshop tingkat nasional dan internasional, serta aktif mengikuti asosiasi profesi ASPENSI dan MSI Jawa Timur. Buku ber-ISBN yang telah dihasilkan 4, yaitu “Pacitan Berjuang (Perjuangan di Pacitan dalam Perang Kemerdekaan tahun 1945-1949”, Nuha Litera, Yogyakarta 2012); “Model Pembelajaran Gotong Royong Teknik Berkirim Salam dan Soal” (Nuha Medika, Yogyakarta, 2014); “Pemanfaatan Budaya Lokal Kabupaten Pacitan sebagai Sumber Belajar” (Oase Pustaka, Surakarta, 2014), “Desain Faktorial : Buku Penunjang Rancangan Percobaan” (LPPM Press, 2018)”. Alamat surel: <a href="mailto:oiing65@gmail.com">oiing65@gmail.com</a></p>
	<p><b>Dwi Cahyani Nur Apriyani, M.Pd.</b> menjadi Pendidik di Program Studi Pendidikan Matematika STKIP PGRI Pacitan sejak tahun 2011. Menamatkan sekolah di Kabupaten Pacitan dan memperoleh gelar S-1 Pendidikan Matematika dari Universitas Negeri Semarang pada tahun 2008. Pada tahun 2012 memperoleh gelar S-2 Pendidikan Matematika dari Universitas Negeri Sebelas Maret Surakarta dan saat ini sedang menempuh Pendidikan Doktor pada Program Studi Ilmu Pendidikan di Universitas Negeri Yogyakarta. Selain melakukan kegiatan mengajar, penulis aktif melakukan penelitian dan pengabdian baik. Penulis juga senantiasa aktif mengikuti</p>

	<p>kegiatan ilmiah baik sebagai pemakalah dalam seminar nasional dan internasional, maupun sebagai penulis artikel pada jurnal ilmiah. Penulis telah menghasilkan buku ber-ISBN, yaitu “Desain Faktorial: Buku Penunjang Rancangan Percobaan” (LPPM Press, 2018)”. Untuk korespondensi dengan penulis dapat melalui surel <a href="mailto:yaa_latiif@yahoo.com">yaa_latiif@yahoo.com</a></p>
--	--



**RANCANGAN PERLAKUAN** adalah rancangan untuk menetapkan unit eksperimental ke tingkat perlakuan dan analisis statistik yang terkait dengan rancangan tersebut. Salah satunya adalah Desain Faktorial 4 Faktor.

Desain faktorial menjadi pilihan penting pada rancangan penelitian eksperimen karena memiliki fleksibilitas yang tinggi untuk mengeksplorasi atau meningkatkan variasi perlakuan serta efisien untuk menguji efek utama dan interaksi antar faktor atau variabel penelitian.

Komposisi dari suatu perlakuan dapat dibentuk dari satu faktor, dua faktor, atau lebih. Faktor adalah peubah bebas atau variabel yang digunakan dalam percobaan sebagai penyusun struktur perlakuan.

Buku ini selanjutnya membahas tentang Rancangan Perlakuan untuk Desain Faktorial Empat Faktor di mana perlakuan yang diuraikan ada yang bersilangan, tersarang, dan campuran antara bersilangan dan tersarang. Bentuknya berupa Model Diagram Blok disertai dengan Model Tabel Anava.

